



Service Manual

AudioScope™/ AudioScope 3™

Screening Audiometers

Single Hearing Level Models: 23020, 23000, 23040

Three Hearing Level Model 23300

Charging Stand 71123

Charging Transformers: Australia - 71036, Europe - 71032, Japan -71030,
United Kingdom 71034, United States - 71040

PN: 230260 Rev. B

Welch Allyn, Inc.
4341 State Street Road
P.O. Box 220
Skaneateles Falls, NY 13153-0220
Copyright 2004

Revision History

ECN#/ ECO#	Revision	Date	Section	Title	Author	Description
5-32904	A	5/31/96	1	General Info.	RJS	Intro of Document
5-32904	A	5/31/96	2	Service	RJS	Intro of Document
5-32904	A	5/31/96	3	Troubleshooting	RJS	Intro of Document
5-32904	A	5/31/96	4	Disassembly/Repair	RJS	Intro of Document
5-32904	A	5/31/96	5	Drawings/Specs.	RJS	Intro of Document
1001574	B	6/17/04		Soldering	BSW	Added Soldering Temperatures

Drawings and/or illustrations and/or part numbers in this document are for reference only. For the most current revision call the Welch Allyn Customer Service phone number listed in Section 1.

Table of Contents

	Sub Sect	Pg.
Cover Page		1
Revision Page		3
Table of Contents		4-5
SECTION 1: General Information		
To Service Personnel	1.1	7
Limited Warranty	1.2	8
Introduction to AudioScopes	1.3	9-11
Figure 1.3 AudioScope Handle Controls	1.3	11
Basic System Description (Fig.1.4a Basic System)	1.4a	12
Basic System Description (charging stand)	1.4b	12
Use of the AudioScope (Screening)	1.5	13-14
Operating Program 1-Lev (Fig 1.6 Block Diagram)	1.6	15-17
Operating Program 3-Lev (s/n<=969999) ASIC	1.7a	18-20
Operating Program 3-Lev (s/n>=970000)nonASIC	1.7b	21-22
Technical Functional Specifications (All Models)	1.8	23
SECTION 2: Service		
Intent of Service Manual	2.1	25
Repair Parts for AudioScope	2.2	26
Lists of Tools/Fixtures/Documents for Service	2.3a	27-28
Fig. 2.3b Tools/Fixtures Setup for Calibration for AudioScope and AudioScope 3 s/n<=969999	2.3b	29
Fig. 2.3c Tools/Fixtures Setup for Calibration for AudioScope 3 s/n>=970000	2.3c	30
Training	2.4	31
Calibration (Single Level 23020,23000,23040)	2.5	32-33
Figure 2.5.4 Sound Tube Placement/Adjustment	2.5	32
Calibration (Multi Level 23300) s/n <=969999	2.6	34-35
Calibration (Multi Level 23300) s/n >=970000	2.7	36-37
SECTION 3: Troubleshooting 23300		
Troubleshooting AudioScope 3 s/n <=969999	3.1	39
Troubleshooting AudioScope 3 s/n >=970000	3.2	40
SECTION 4: Disassembly and Repair, AudioScope 3		
Handle	4.1	43-45
Charging stand	4.2	46

Table of Contents CONTINUED

SECTION 5: Drawings/ Test Specifications

Manilla Pockets contain 17" x 22" drawings. 5.1 49

Drawing#	Description	Original Size/#sheets
A02030	Repair Calibration Spec. for AudioScope II	B/1 of 1
A00277	Audiometer Handle Test Specifications	D/1 of 1
A00984	P.C.B. Test Spec AudioScope II	D/1 of 1
A00273	Electronics Module Test Specification	D/1 of 2
A00273	Electronics Module Test Specification	D/2 of 2
A00985	Audio Module III Test Spec	D/1 of 1
A01825	AudioScope III Sound Equipment Calibration and Setup	C/1 of 1
A00942	Charging Stand Electrical Test Spec.	A/1 of 1
230230	Audio II Schematic (PCB for <u>ASIC version</u>)	D/1 of 1
230215	PC Board Ass'y (for <u>ASIC version</u>)	D/1 of 1
236630	PCB Schematic (for <u>Microcontroller version</u>)	B

Parts catalog pages

230137-3	Nos.23000, 23020, 23040 AudioScope	A/1 of 1
230237-1	No. 23300 AudioScope II and 3	A/1 of 1
711408-2	No. 71123 Charging Stand	A/1 of 1

Section 1:

General Information

1.1 To Service Personnel

Read and understand the AudioScope operating instructions manual pn. 230231-2. The information in this Service Manual is subject to change without notice and should not be construed as a commitment by Welch Allyn. Welch Allyn assumes no responsibility for any errors that may appear in this manual.

Who to contact:

If the product and/or its operation varies significantly from any description therein, please contact:

Welch Allyn Medical Products Division

Product Service Department,

4341 State Street Road, Skaneateles Falls, NY, 13153-0220, U.S.A.

Phone (315) 685-4445, or (800) 669-9771.

Fax (315) 685-4653

This product has been designed to provide a high degree of safety and reliability. However, we cannot guarantee against the deterioration of components due to aging and normal wear.

All service and repairs must be done by authorized Welch Allyn personnel or agents, using approved Welch Allyn replacement parts and approved process materials. Failure to do so will invalidate the product warranty. Please refer to the product warranty for specific coverage.

USING ADHESIVES: ALWAYS WEAR SAFETY GLASSES AND PROVIDE ADEQUATE VENTILATION WHEN USING CA ADHESIVES, CA ACCELERATORS, AND RTV ADHESIVE SEALANTS. READ AND OBEY WARNINGS, CAUTIONS, INSTRUCTIONS, AND RECOMMENDATIONS PRINTED ON CONTAINER AND CORRESPONDING MSDS SHEETS

CAUTION: PRIOR TO DOING REPAIR WORK, UNPLUG POWER CORD ON CHARGER TO ELIMINATE SHOCK HAZARD. USE GROUNDING MAT AND GROUNDING STRAP TO REDUCE CHANCES OF DAMAGE TO ASIC IN HANDLE.

1.2 Limited Warranty

Welch Allyn warrants the AudioScope, when new, to be free of defects in material and workmanship and to perform in accordance with the manufacturer's specifications for a period of one year from the date of purchase from Welch Allyn or its authorized distributors or agents.

Welch Allyn will either repair, replace or recalibrate any components (except lamps) found to be defective or at variance from the manufacturer's specifications within this time at no cost to the customer, except for transportation expenses. For rechargeable batteries, warranty is extended to two years. It shall be the purchaser's responsibility to return the instrument directly to Welch Allyn or to an authorized distributor, agent or service representative.

This warranty does not include breakage or failure due to tampering, misuse, neglect, accidents, modification or shipping. This warranty is also void if the instrument is not used in accordance with the manufacturer's recommendations or if repaired by other than a Welch Allyn or authorized agent. This warranty can be extended to a three-year period provided the instrument is returned for recalibration annually. Submission of instrument registration card is required. Purchase date determines warranty and recalibration requirements. No other express warranty is given.

To receive service assistance or to ask questions regarding this warranty, please call or write:

Welch Allyn Product Service Dept.
Welch Allyn, Inc.
Medical Products Division
4341 State Street Road
Skaneateles Falls, New York 13153 USA
1 (800) 669-9771 or (315) 685-4445

Note: The U.S. Occupational Safety and Health Administration (OSHA) recommends that audiometers be calibrated annually. Arrangements for calibration can be made by returning the instrument registration card. In addition a daily biological check may be performed. This is accomplished by a person with known normal hearing who listens to the tones for intensity and quality. There is a moderate fee for recalibration. *Re-printed from PN230108, Instrument Registration Card

1.3 Introduction to AudioScopes

The Welch Allyn AudioScope (audiometer) enables the practitioner to perform a fast, painless and objective test for early hearing loss. The AudioScope3 starts with a Practice Tone (PT) of 1,000 Hz at a dB HL dependent upon the selected Screening dB HL. (Refer to Page 5 of Operating Instructions). After the Practice Tone (PT), the AudioScope3 provides screening at all four speech frequencies: 1,000 Hz, 2,000 Hz, 4,000 Hz, and 500 Hz. This test can be performed at one of three hearing levels: 20 dB, 25 dB, or 40 dB. Selection of the hearing level is dependent on the age of the patient. Note: there is no PT with single level AudioScopes. If a hearing problem is suspected, the patient is referred to a specialist for diagnosis.

The AudioScope contains a 3.5-volt halogen lamp and otoscope lens for viewing the tympanic membrane and the ear canal prior to and during hearing screening.

There are two types of Welch Allyn AudioScopes in use today:

- The first type is the **single hearing level** instrument of which there are three models. Although they are obsolete, they can still be calibrated if they are functioning according to specifications. Service parts are not available.
 - AudioScope pn 23020 - 20 dB (no PT)
 - AudioScope pn 23000 - 25 dB (no PT)
 - AudioScope pn 23040 - 40 dB (no PT)
- The second type is the **three hearing level (MultiLevel) AudioScope3**. (Also known as AudioScope II) There are two versions of this second type.
 - AudioScope3 pn 23300 - 20, 25, 40 dB (1000 Hz PT)

The **original version** of the AudioScope 3 (**three hearing level**) up to and including serial number 969999 utilizes an ASIC module. This instrument is calibrated by adjusting miniature potentiometers on the printed circuit board. Although the main board/ASIC is being phased out at the time of this writing, they can still be calibrated if they are functioning according to specifications. Some parts are available. (See Repair Parts, Section 2.2)

NEW VERSION:

A **new version** (starting in 1996 with serial number 967000) differs from the first AudioScope3 in that a Microcontroller is used instead of the ASIC. Performance specifications of the new AudioScope 3 are identical to the earlier AudioScope 3, and the part number remains the same. Since this version utilizes a Microcontroller with digitally adjusted pots and not mechanical potentiometers, calibration is much easier. Tool T-13765 is used to electronically adjust the board. This advance eliminates the limitations of mechanical potentiometers and reduces calibration time.

1.3 Introduction to AudioScopes

The operation and calibration of all five of these screening audiometers are explained in this manual.

Important note to Service Personnel

Board Replacement on AudioScope 3:

Welch Allyn manufactures only the AudioScope3 as of Oct. 1986. As of 1996, starting with serial no.967000 a new version AudioScope3 utilizes a Microcontroller (does not have ASIC) and is calibrated using the T-13765 Calibrator Box. It has digital potentiometers for calibration, not mechanical pots. All previous models were calibrated using mechanical potentiometer. Calibration of all types of AudioScopes is explained in this manual. If the ASIC fails on an AudioScope 3, the whole board will be replaced with the new board containing the digitally adjustable Microcontroller. This board will fit the AudioScope3 with no modifications. Unit performance is the same.

Obsolescence of Single Level AudioScope:

Single Level AudioScopes are over ten years old. Service Parts are not available. Recalibrations CAN be performed on properly functioning single level AudioScopes. For failed units, save the lamp, battery, and charging stand/transformer for use with AudioScope3.

1.3 Introduction to AudioScopes

AudioScope 3 Handle Controls and features are shown in the figure below.

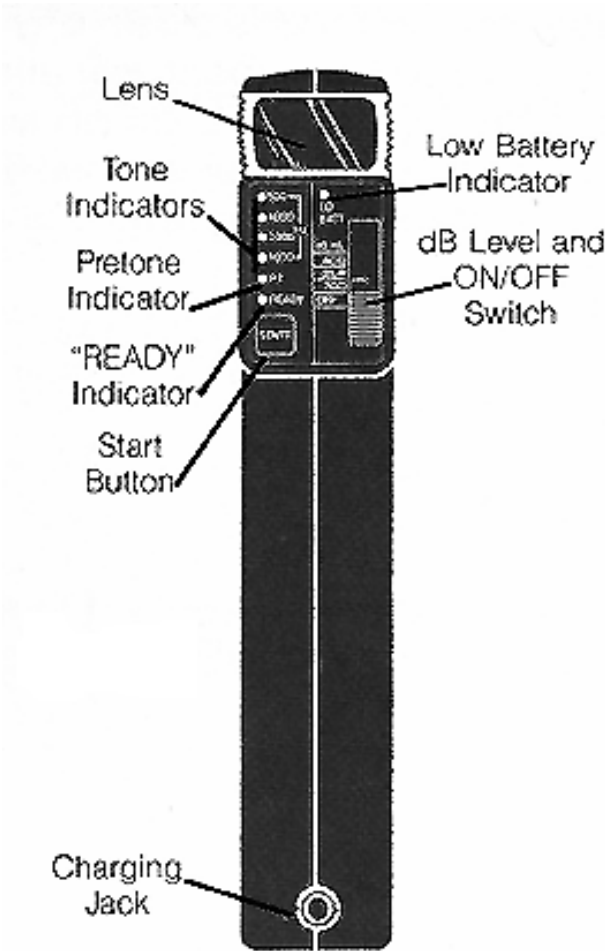

1.4a Basic System Description

There are three components to the Welch Allyn AudioScope: the hand held AudioScope handle, the Charger stand and transformer.

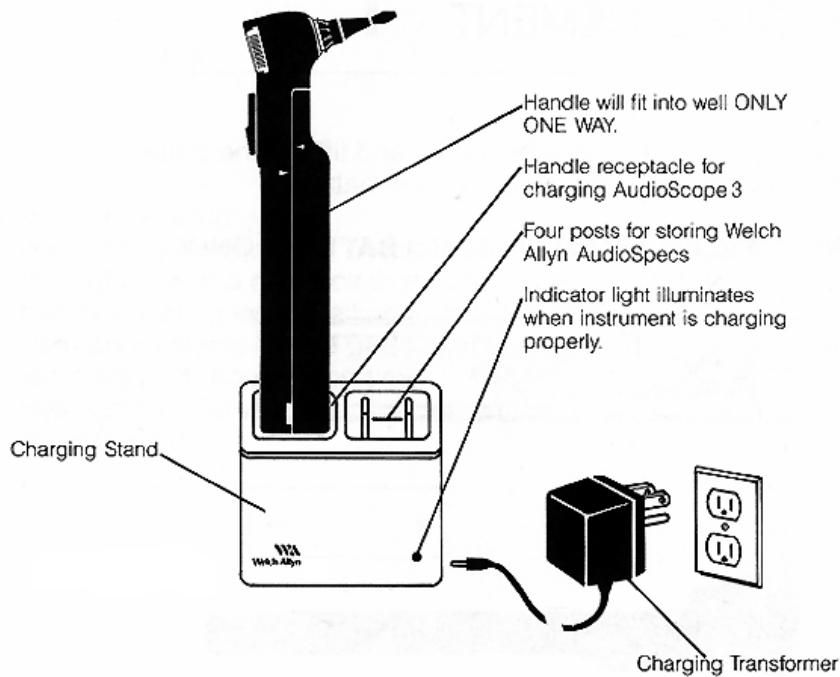

1.4b AudioScope Charging Stand

The charging stand holds the handle and specs and is the interface between the Handle and the charging current of the wall transformer. Insertion of the handle into the charging well completes the charging circuit. An LED illuminates when the handle is in the well and the charging circuit is complete.

1.5 Use of the AudioScope (Screening)

Read pg. 6-8 of Operating Instructions pn230231-2 (shown below) for full details of the screening procedure.

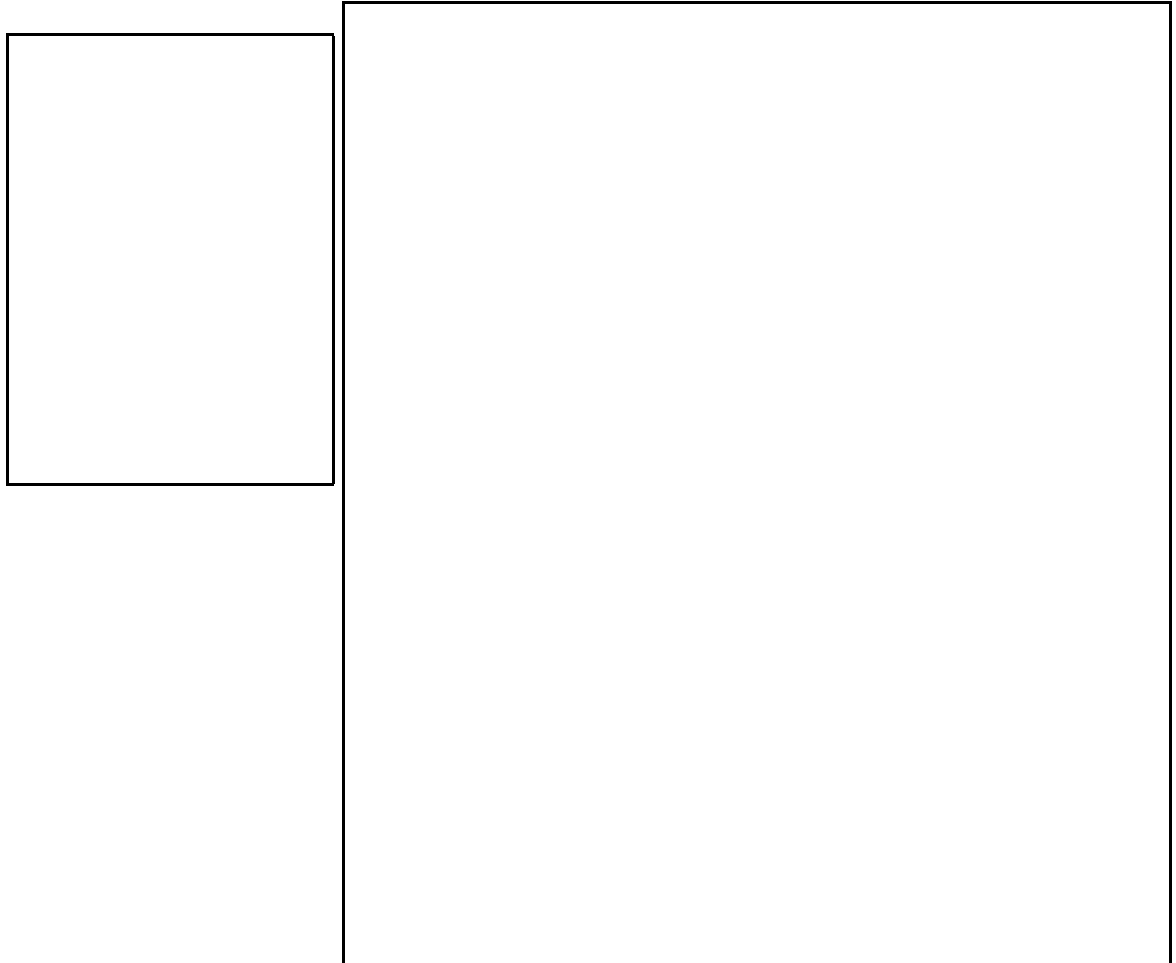

Note: The following excerpt is only an outline intended for general familiarization by service personnel. This outline is not intended to replace above referenced Operating Instructions pn 230231-2.

1. Check that lens is centered in the instrument.
2. Select an area that is relatively quiet and free from distracting sounds.
See page 26 of Operating Instructions for Maximum Permissible Ambient Noise for the different screening levels.
3. Select appropriate size specula and twist onto instrument. **USE ONLY GRAY-TIPPED WELCH ALLYN AUDIOSPECS.**

1.5 Use of the AudioScope (Screening) continued

4. Turn AudioScope3 "ON" by sliding the selection switch to the desired screening level.
5. Instruct patient to respond appropriately to sound. Insert the tip of the speculum into the ear canal. Position the tip so that the tympanic membrane or a portion of it can be visualized.
6. Depress **START** button and observe each tone and the patient's response. Repeat these steps for opposite ear.
7. Remove instrument from patient's ear and turn off. Return to the Charging stand. (REFER TO Operating Instructions).

1.6 Operating Program of Models 23020, 23000, 23040 Single Hearing Level AudioScope

NOTE: Since these models of AudioScopes are well over ten years old, the circuitry is no longer available. If this circuitry fails, the Single Level AudioScope is no longer repairable. Recalibrations **CAN** be performed if the unit is functioning properly. If the unit fails, however, the lamp, battery, and charging stand/transformer can be re-used with the AudioScope3.

See Fig. 1-6 Block Diagram of Welch Allyn AudioScope.

- **SINGLE HEARING LEVEL** AudioScope models (20,25,40 dB) use the same basic circuitry except for **the value of R 21 and the adjustments on VR2.**

Model:	Ohms of R21:
20 dB AudioScope =	11 Ohms
25 dB AudioScope =	20 Ohms
40 dB AudioScope =	130 Ohms



1.6 Operating Program: 23020, 23000, and 23040 Single Hearing Level AudioScope

<u>Sequence:</u>	<u>Cause:</u>	<u>Effect:</u>
1. Manual	Switch "ON"	Lamp "ON", Ready LED "ON"
2. Manual	Press "START"	U4 activated
3. Logic	pin 11 goes to 0v U4 pulls pin 20 to 0v this charges C5 U4 also selects resistance between pin 14 of U4 and pin 5 of U3.	activates LED (500 Hz LED.) selects resistance between pin 7 of U2 and ground. produces 500 Hz sine wave at pin 2 of U2 this resistance is adjusted for the output amplitude of the 500 Hz tone only and is used to control output amplifier U3.

(Process repeats for the 1000 Hz, 2000 Hz, and 4000 Hz tones.)

4. Logic	pin 4 goes to 0v U4 pulls pin 22 to 0v this charges C5 U4 also selects resistance between pin 15 of U4 and pin 5 of U3.	activates LED (1000 Hz LED.) selects resistance between pins 7 of U2 and ground. produces 1000 Hz sine wave at pin 2 of U2 this resistance is adjusted for the output amplitude of the 1000 Hz tone only and is used to control output amplifier U3.
5. Logic	pin 12 goes to 0v U4 pulls pin 21 to 0v this charges C5	activates LED (2000 Hz LED.) selects resistance between pin 7 of U2 and ground. produces 2000 Hz sine wave at pin 2 of U2

1.6 Operating Program: 23020, 23000, 23040

Single Hearing Level AudioScope continued

<u>Sequence:</u>	<u>Cause:</u>	<u>Effect:</u>
	U4 also selects resistance between pin 17 of U4 and pin 5 of U3.	this resistance is adjusted for the output amplitude of the 2000 Hz tone only and is used to control output amplifier U3.
6. Logic	pin 3 goes to 0v	activates LED (4000 Hz LED.)
	U4 pulls pin 1 to 0v	selects resistance between pin 7 of U2 and ground.
	this charges C5	produces 4000 Hz sine wave at pin 2 of U2
	U4 also selects resistance between pin 16 of U4 and pin 5 of U3.	this resistance is adjusted for the output amplitude of the 4000 Hz tone only and is used to control output amplifier U3.
7. Logic	cycle completes itself	Ready LED illuminates
8. Manual	switch off	<u>unit deactivates, lamps & logic off</u>

1.7a Operating Program: 23300 (ASIC TYPE) up to and including serial no.9609999

Multi-Level AudioScope3 ASIC

The Three Hearing Level AudioScope3 up to and including Serial Number 960999 uses an ASIC (single application specific integrated circuit) Microprocessor. This component *is not a service part. If the ASIC Microprocessor should fail, it will be necessary to replace the Circuit Board/ASIC assembly with the new Microcontroller based circuit board Part No.* This is an easy replacement and does not affect unit operation. Calibrate the *Microcontroller* based AudioScope3 with T-13765 AudioScope Calibrator Box explained in Section 2.7.11

Tone Generation:

External resistors and capacitors are used to generate four different tones at hearing levels of 20, 25, 40 dBs. The output amplitude is determined by SW2, which selects one resistor for a hearing level of 20, 25, or 40 dBs respectively.

Operation begins with switching the unit *ON*. The examination halogen lamp illuminates immediately. When the start button is depressed, the AudioScope begins to generate a sequence of tones starting with PT of 1000 Hz, which is 20 dB higher than the manually selected specific hearing level. Then the 1000 Hz, 2000 Hz, 4000 Hz and 500 Hz tones are generated in that order at the same hearing level. When the cycle is complete, the AudioScopes returns to the ready state indicated by the Green "Ready" LED. The whole cycle is completed in less than 20 seconds.

1.7a Operating Program: 23300 (ASIC TYPE) up to and including serial no.9609999

Multi-Level AudioScope3 ASIC

<u>Sequence:</u>	<u>Cause:</u>	<u>Effect:</u>
1. Manual	Switch "ON"	Lamp "ON", Ready LED "ON"
2. Manual	Press "START"	ASIC activated
3. Logic	pin 20 goes low PreTone 1kHz sine wave appears at ASIC Pin 4 and is amplified and then applied to speaker from ASIC Pin 7	activates PT (PreTone) LED (D6) Speaker produces 1 kHz PreTone

(General cycle is repeated for TEST tones: 1000 Hz, 2000 Hz, and 4000 Hz and 500 Hz)

4. Logic	ASIC Pin 21 goes low 1kHz sine wave appears at ASIC Pin 3 and is amplified and then applied to speaker from ASIC Pin 7	activates 1 kHz LED (D5) Speaker produces 1 kHz Tone
5. Logic	ASIC Pin 22 goes low 2kHz sine wave appears at ASIC Pin 6 and is amplified and then applied to speaker from ASIC Pin 7	activates 2 kHz LED (D4) Speaker produces 2 kHz Tone
6. Logic	ASIC Pin 23 goes low 4kHz sine wave appears at ASIC Pin 5 and is amplified and then applied to speaker from ASIC Pin 7	activates 4 kHz LED (D3) Speaker produces 4 kHz Tone

1.7a Operating Program: 23300 (ASIC TYPE) up to and including serial no.9609999

Multi-Level AudioScope3 ASIC

<u>Sequence:</u>	<u>Cause:</u>	<u>Effect:</u>
7. Logic	ASIC Pin 24 goes low 500 Hz sine wave appears at ASIC Pin 2 and is amplified and then applied to speaker from ASIC Pin 7	activates 500 Hz LED (D2) Speaker produces 500 Hz Tone
8. Logic	cycle completes itself and activates D1	Ready LED illuminates
9. Manual	switch off	<u>unit deactivates, lamps & logic off</u>

1.7b Operating Program: 23300 (Microcontroller type serial no.9670000 and higher)

Multi-Level AudioScope3 (Microcontroller/non ASIC)

<u>Sequence:</u>	<u>Cause:</u>	<u>Effect:</u>
1. Manual	Switch "ON"	Lamp "ON", Ready LED "ON"
2. Manual	Press "START"	MICRO activated
3. Logic	U4 pin 9 goes to 3 V	activates PT (PreTone) LED (D3)
4. Logic	U4 pulses pin 4	U4 ramps U5 (digital pot) to calibrated level. This establishes feedback resistance for U3C.
	U4 sequentially toggles pin 19, 20, 21, 22	Generates digital base amplitude sinewave at pin TP10
<i>General cycle is repeated for TEST tones : 1000, 2000, 4000, and 500 Hz.</i>		
5. Logic	U4 pin 8 goes to 3 V	activates 1000 Hz LED (D4)
	U4 pulses pin 4	U4 ramps U5 (digital pot) to calibrated level. This establishes feedback resistance for U3C.
	U4 sequentially toggles pin 19, 20, 21, 22	Generates digital base amplitude sinewave at pin TP10
6. Logic	U4 pin 7 goes to 3 V	activates 2000 Hz LED (D5)
	U4 pulses pin 4	U4 ramps U5 (digital pot) to calibrated level. This establishes feedback resistance for U3C.
	U4 sequentially toggles pin 19, 20, 21, 22	Generates digital base amplitude sinewave at pin TP10

1.7b Operating Program: 23300 (Microcontroller type serial no.9670000 and higher) (continued)

Multi-Level AudioScope3 (Microcontroller/non ASIC)

<u>Sequence:</u>	<u>Cause:</u>	<u>Effect:</u>
7. Logic	U4 pin 6 goes to 3 V	activates 4000 Hz LED (D6)
	U4 pulses pin 4	U4 ramps U5 (digital pot) to calibrated level. This establishes feedback resistance for U3C.
	U4 sequentially toggles pin 19, 20, 21, 22	Generates digital base amplitude sinewave at pin TP10
8. Logic	U4 pin 5 goes to 3 V	activates 500 Hz LED (D7)
	U4 pulses pin 4	U4 ramps U5 (digital pot) to calibrated level. This establishes feedback resistance for U3C.
	U4 sequentially toggles pin 19, 20, 21, 22	Generates digital base amplitude sinewave at pin TP10
9. Logic	cycle completes itself and activates D2	Ready LED illuminates
10. Manual	switch off	<u>unit deactivates, lamps & logic off</u>

Section 2:

Service

2.1 Intent of Service Manual

This manual provides technical assistance to trained service personnel for diagnosing, repairing, calibrating/testing the AudioScope handle and Charging Stand and replacing parts listed in Section 2.2. See the table of contents for a complete listing of manual contents.

Welch Allyn part numbers (PN#), and material numbers (M#), appearing in this manual are current at the date of publication. Order replacement parts by referencing your latest bill of materials or parts catalog. Part number changes, product updates, or new test procedures should be noted on the appropriate page of this manual by the manual owner. Notices announcing these changes should be attached to the manual.

Caution: prior to doing repair work, unplug power cord on charger to eliminate shock hazard. Use grounding mat and grounding strap to reduce chances of damage to ASIC in handle.

Caution when using adhesives: Always wear safety glasses and provide adequate ventilation when using adhesives, accelerators, and RTV adhesive sealants. Read and follow all appropriate recommendations in corresponding MSDS sheets.

2.2 Repair Parts for AudioScopes

Note: Order parts from most recent Bill of Materials/Repair:
The attached bill of materials shows replacement parts, which are available from Welch Allyn.

<u>Part number</u>	<u>Description</u>
711427-501	Housing assembly Charging stand
711413	Holder f/handle & specula
711419-501	Rubber feet (set of 4)
711418-501	Base plate assembly
711421	Mounting hardware kit
711420	#6 x 3/4 PHPS HD screw self tap
230035-2	Miniature transducer
230038	Transducer boot
230029-1	Stabilizing grommet
200055-502	Lens holder assembly
230073-505	Housing assembly
230080-502	Cover assembly
230201-501	Electronics module assembly AS3*
710205	Power jack
72300	3.5-volt rechargeable battery
06200	3.5-volt halogen lamp

*Single level AudioScope modules pn 230001-501 are No longer Available.

2.3a Lists of Tools/Fixtures/Documents for Service and Calibration*

* The U.S. Occupational Safety and Health Administration (OSHA) recommends that audiometers be calibrated annually. Arrangements for calibration can be made by returning the instrument registration card. In addition a daily biological check may be performed. This is accomplished by a person with known normal hearing who listens to the tones for intensity and quality. There is a moderate fee for recalibration.

Properly trained technicians will need specialized commercially available test equipment, custom made (Welch Allyn T-tools) specialized tools and fixtures, basic electronic hand tools and Welch Allyn specifications and drawings to properly diagnose, calibrate, and repair the AudioScope and charger base.

<u>Item description:</u>	<u>Function:</u>	<u>T #&M#</u>
B&K 2231 Modular Precision Sound Level Meter	Measures sound output	
B&K 4134 1/2" Microphone	Sound pick-up	
B&K 1625 1/3 to 1 Filter	Acoustic filter	
B&K Power Supply (6 V.D.C.)	Powers B&K 2231	
Knowles DB100-R 496 Occluded Ear Simulator	Connects T-1393 and T-2011	
Knowles DB-009 Teflon washers	Seals microphone and DB-100 connection	
Fluke 1900A Frequency Counter (3% accuracy)	Calibration and testing	
Oscilloscope Tektronix 2230A or Equiv. (storage type)	Calibration and testing	
ESD mat and wrist-strap	Repair	
Electronic Technicians hand tools kit	General Repair	
Digital Volt Ohm Meter	Troubleshooting/Repair	
PACE Soldering Equipment* *Set iron to 700°F +/- 27°F	Repair	T19102-2
Rosin Core Solder, .020", 63Sn/37Pb	Repair	M-31446
G.E. RTV 108 (Clear/Thick)	Repair	M-30313
Power Supply (0 - 5 VDC @ 1 Amp)	Testing	T-3769
AudioScope Holding Device	holds AudioScope	T-1539
Coupling Tool for Microphone	Holds AS to DB-100 assembly	T-1393
Latchup Box for AudioScope 1 and AudioScope3 with ASIC s/n <=969999	Holds Tones	T-9783
Microphone Handle Cover	Holds Microphone to DB-100	T-2011
AudioScope Calibrator for Microcontroller digital adjust (non ASIC)		T-13765
Charging jack pin-spanner	charging jack ring nut tool	T-10912

2.3a Lists of Tools/Fixtures/Documents for Service and Calibration*

Drawing#	Description	Size/# sheets
A02030	Repair Calibration Spec. for AudioScope II	B/1 of 1
A00277	Audiometer Handle Test Specifications	D/1 of 1
A00984	P.C.B. Test Spec AudioScope II	D/1 of 1
A00273	Electronics Module Test Specification	D/1 of 2
A00273	Electronics Module Test Specification	D/2 of 2
A00985	Audio Module III Test Spec	D/1 of 1
A01825	AudioScope III Sound Equipment Calibration and Setup	C/1 of 1
A00942	Charging Stand Electrical Test Spec.	A/1 of 1
230230	Audio II Schematic (PCB for <u>ASIC version</u>)	D/1 of 1
230215	PC Board Ass'y (for <u>ASIC version</u>)	D/1 of 1
236630	PCB Schematic (for <u>Microcontroller version</u>)	B
Parts catalog pages		
230137-3	Nos. 23000, 23020, 23040 AudioScope	A/1 of 1
230237-1	No. 23300 AudioScope II and 3	A/1 of 1
711408-2	No. 71123 Charging Stand	A/1 of 1

2.3b Tools and Fixtures Setup for Calibration AudioScope and AudioScope 3



s/n<=969999 (ASIC)

Figure 2.3b Calibration Set-up for AudioScopes with ASIC

2.3c Tools and Fixtures Setup for Calibration

AudioScope 3 s/n ≥ 970000



(Microcontroller)

2.4 Training

The AudioScope is a sophisticated audiometric device and must be serviced and calibrated by trained. They must possess demonstrated skills in this area using specialized and calibrated sound measuring equipment. This Service Manual is the basis for delivering competency-based skills training to technicians or service engineers who already possess knowledge and skills in the use of electronic equipment as listed in the specialized test equipment Section 2.3. They must also be able to properly use certain commercially available equipment and hand tools for diagnosis, calibration, assembly, and board level repairs of the AudioScope and charger base. See Fig.2.3

This manual provides specific information for diagnosing, repairing, calibrating and testing the AudioScope handle and Charging Stand. Refer to the Table of Contents for complete information on the manual.

Use this manual for Self Training. Have an AudioScope system on hand to help with familiarization and repair practice. Read each complete repair step before starting hands-on practice.

Use this manual for Group Training. The technician will acquire and retain service information and service skills for the AudioScope product because of well prepared and executed training sessions. Conduct detailed demonstrations of required repair tasks then allow time for supervised practice. Set up sessions to allow the trainee time to individually practice all repair procedures. Evaluate trainee progress by observing trainee performance and then recording it on the appropriate form. Each trainee must have the opportunity to practice the procedure(s) after the instructor has demonstrated it.

- Tell them how and why.
 - Show them how with explanations.
 - Provide for supervised practice by the trainees.
- Record results and conduct follow-up training as necessary.

2.5 Calibration Procedure: Single Level AudioScope

- **Incoming bench checks:** Prepare the AudioScope for calibration.
 - 2.5.1 ___ Check the tightness of the two slotted screws near battery positive spring
 - 2.5.2 ___ Check the tightness of the charger jack
 - 2.5.3 ___ Remove RTV from the potentiometers
 - 2.5.4 ___ Check that the sound tube extends at least 1/16" to 1/8" into the cavity behind the lens. If it does not, move it upwards. Use fingers. Long nose pliers could bend or crush the sound tube
See Figure 2.5.4 below

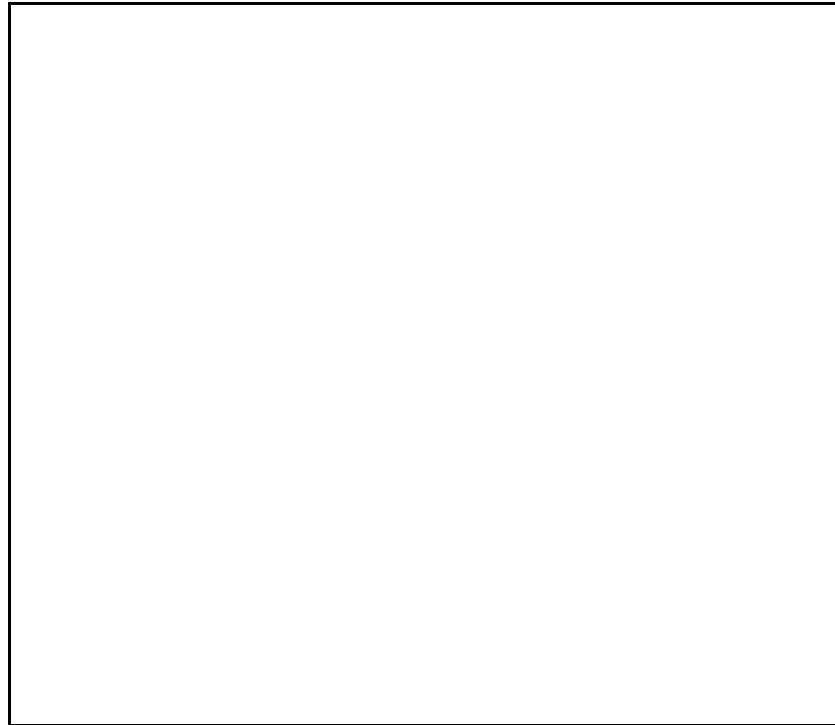

- **Preparation of Sound Equipment:**
 - 2.5.5 ___ Set up your sound equipment as per "AudioScope II Sound Equipment Calibration and Setup Procedure A01825"

2.5 Calibration Procedure: Single Level AudioScope

- **Calibration:**
Materials Required: Audiometer Handle Test specification A00277
1 sheet (This is the process.)
Electronics Module Test Specification, A00273
2 sheets (These are the specifications.)

Note :A note appearing on the specification reads"Exact Measurements are not required for 100% inspection". This note does not apply to sound settings.
Adjust the AudioScope according to the printed sound settings and their tolerances as shown on the print.

<u>Your Sequence:</u>	<u>Original Step number from A00277:</u>	<u>Modifications if</u>	
		<u>any:</u>	
• 2.5.6 ____	step 1	Start Button	Check for smooth operation.
• 2.5.6 ____	step 2	On/Off Switch	
• 2.5.7 ____	step 3	L.E.D.s	LED.s must be bright.
• 2.5.8 ____	step 4	Rattle	
• 2.5.9 ____	step 7	Cover	
• 2.5.10 ____	step 8	Pneumatic Seal	Check seal before sound.
• 2.5.11 ____	step 5	Sound Level	
• 2.5.12 ____	step 9	Charge	
• 2.5.13 ____	step 10	Lamp Ejector	
• 2.5.14 ____	step 11	Trained Listener	

Calibration is complete.

If Single level AudioScope does not take calibration, unit is not serviceable.
Customer should be advised that unit is obsolete, parts are not available .
Lamp, battery, and charging system can be used on new AudioScope 3.

2.6 Multi Level AudioScopes (AudioScope#) 23300 (ASIC TYPE) up to and including serial no.9609999

- **Incoming bench checks:** Prepare the AudioScope for calibration.
 - 2.6.1 ___ Check the tightness of the two slotted screws near battery positive spring
 - 2.6.2 ___ Check the tightness of the charger jack
 - 2.6.3 ___ Remove RTV from the potentiometers
 - 2.6.4 ___ Check that the sound tube extends at least 1/16" to 1/8" into the cavity behind the lens. If it does not, move it upwards with long nose pliers taking care not to bend or crush the sound tube. See Figure 2.5.4

- **Preparation of Sound Equipment:**
 - 2.6.5 ___ Set up your sound equipment as per "AudioScope II Sound Equipment Calibration and Setup Procedure A01825"

- **Calibration:**
 Materials Required: Audiometer Handle Test Specifications A00277
 1 sheet (This is the process.)
 Electronics Module Test Specification, A00985
 1 sheet (These are the specifications.)

Note: A note appearing on the specification reads "Exact Measurements are not required for 100% inspection". This note does not apply to sound settings.

Adjust the AudioScope according to the printed sound settings and their tolerances as shown on the print.

<u>Sequence:</u>	<u>Original Step number from A00277:</u>	<u>Modifications if</u>
	<u>any:</u>	
• 2.6.6 ___	step t1 Start Button	Check for smooth operation.
• 2.6.7 ___	step t2 On/Off Switch	
• 2.6.8 ___	step 3 L.E.D.s	LED.s must be bright.
• 2.6.9 ___	step 4 Rattle	
• 2.6.10 ___	step 7 Cover	
• 2.6.11 ___	step 8 Pneumatic Seal	Check seal before sound.
• 2.6.12 ___	step 5 Sound Level	
• 2.6.13 ___	step 9 Charge	

2.6 Multi Level AudioScopes 23300 (ASIC TYPE) up to and including serial no.9609999

- Calibration: Continued

Sequence: Original Step number from A00277: Modifications if
any:

- 2.6.14____ step 10 Lamp Ejector
- 2.6.15____ step 11 Trained Listener

Calibration is complete.

If AudioScope3 (ASIC) does not take calibration, proceed to troubleshooting section. After repair of the AudioScope3, calibrate. If the unit cannot be repaired, replace the failed AudioScope 3 ASIC board with a new style Microcontroller based board and calibrate it according to instructions in Section 2.7.

2.7 Calibration Procedure, Multi Level AudioScopes 23300 (MICROCONTROLLER type, serial no.9670000 and higher)

- **Incoming bench checks:** Prepare the AudioScope 3 for calibration.
 - 2.7.1 ___ Check the tightness of the two slotted screws near battery positive spring.
 - 2.7.2 ___ Check the tightness of the charger jack.
 - 2.7.3 ___ Check that the sound tube extends at least 1/16" to 1/8" into the cavity behind the lens. If it does not, move it upwards with long nose pliers taking care not to bend or crush the sound tube.
- **Preparation of Sound Equipment:**
 - 2.7.4 ___ Set up your sound equipment as per "AudioScope II Sound Equipment Calibration and Setup Procedure A01825"
- **Calibration:**
Materials Required: Audiometer Handle Test Specifications A00277
1 sheet (This is the process.)
Electronics Module Test Specification, A00985
1 sheet (These are the specifications.)

Note :A note appearing on the specification reads"Exact Measurements are not required for 100% inspection". This note does not apply to sound settings.
Adjust the AudioScope according to the printed sound settings and their tolerances as shown on the print.

<u>Your Sequence:</u>	<u>Original Step number from A00277:</u>	<u>Modifications if any:</u>
• 2.7.5 ___ step 1 Start Button		Check for smooth operation.
• 2.7.6 ___ step 2 On/Off Switch		
• 2.7.7 ___ step 3 L.E.D.s		LED.s must be bright.
• 2.7.8 ___ step 4 Rattle		
• 2.7.9 ___ step 7 Cover		
• 2.7.10 ___ step 8 Pneumatic Seal		Check seal before sound.

2.7 Calibration Procedure, Multi Level AudioScopes 23300 (MICROCONTROLLER type, serial no.9670000 and higher) (continued)

- 2.7.11_____ step 5 **Sound Level: Follow steps "a" - "h" below.**
 - a___ Set Run/Cal switch on T-13765 to **"RUN"** position.
 - b___ Attach AudioScope Calibration Box T-13765 to 8 pin header connector with orange wire of T-13765 connector towards crystal.
 - c___ Turn AudioScope3 On and set to "25 dB"
Observe Green LED. It should be lit.
 - d___ Place the RUN/CAL switch on the cal box to the **"CAL"** position. The green READY light should flash. The orange PT (PreTone) light should be on.
 - e___ Use the 1000 Hz filter on the B&K, adjust the PreTone level to the specified level per A00985 (in Section 5 of this manual), using the UP and DOWN buttons on T-13765. (The level will change in prescribed increments each time the buttons are depressed.
 - f___ When desired level is set, depress the SAVE & INCR button.
The handle will move to the next tone to be adjusted.

Repeat above sequence for all remaining frequencies. Select correct filter on B&K.

- g___ Switch unit to 40 dB. Repeat above process only checking readings are in tolerance, but not making adjustments. Switch unit to 20 dB. Repeat checking.
 - h___ Switch the RUN/CAL switch RUN position. Microcontroller AudioScope3 is now calibrated, and will run with new settings.
- 2.7.12_____ step 9 **Charge**
 - 2.7.13_____ step 10 **Lamp Ejector**
 - 2.7.14_____ step 11 **Trained Listener**

Calibration is complete. If AudioScope3 (Microcontroller) does not take calibration, proceed to troubleshooting section. After repair of the AudioScope3, calibrate.

Section 3:

Troubleshooting

3.1 Troubleshooting AudioScope 3 s/n <=969999 (ASIC)

Complaint	Cause	Corrective Action
Unit does not turn on. Green LED does not light.	Low battery voltage.	Substitute with charged test battery and retest. Replace battery. Retry. If green LED remains unlit, replace board.
	Cold solder joint at battery terminal.	Restore connection by reflowing joint (using T19102-2).
	Defective contact in power jack will not close when charge plug is removed.	Replace power jack.
Low battery voltage	Defective power jack	Replace housing.
	Defective charging circuit	Inspect circuit. Restore.
Speaker does not produce tones.	Cold solder joint at speaker or wire to PCB.	Restore connection by reflowing joint (using T19102-2).
	Broken speaker wire	Repair wire.
	Defective speaker	Replace speaker.
	No voltage at TP2	Replace Board
4-K range does not calibrate.	Defective speaker	Replace Speaker. If still does not cal, replace PCB and retest.
Housing fails air seal test.	Gasket not seated correctly	Remove lens assembly and rotate 180 degrees. Reinstall and retest.
	Leaking Lens Gasket	Replace housing.
	Leaking Stabilizing Grommet	Replace
	Defective housing	Replace housing.
Halogen lamp does not light.	Low battery voltage.	Recharge or replace battery.
	Defective halogen lamp.	Replace.
Handle does not charge.	Bent or broken charging contacts in charging well.	Re-shape contact(s) Replace Housing Assembly
Excessive battery drain.	Shorted lamp.	Replace Lamp.

3.2 Troubleshooting AudioScope 3 s/n >=970000 (MICROCONTROLLER / NON-ASIC)

Complaint	Cause	Corrective Action
Unit does not turn on. Green LED does not light.	Low battery voltage.	Substitute with charged test battery and retest. Replace battery. Retry. If green LED remains unlit, replace board.
	Cold solder joint at battery terminal.	Restore connection by reflowing joint (using T19102-2).
	Defective contact in power jack will not close when charge plug is removed.	Replace power jack.
Low battery voltage	Defective power jack	Replace housing.
	Defective charging stand	Check circuit and restore.
Speaker does not produce tones.	Cold solder joint at speaker or wire to PCB.	Restore connection by reflowing joint (using T19102-2).
	Broken speaker wire	Repair wire.
	Defective speaker	Replace speaker.
	No voltage at TP2	Replace Board
Does not calibrate at a particular frequency.	Defective speaker	Replace Speaker. If still does not cal, replace PCB and retest.
Does not calibrate at any frequency.	Call box plugged in backwards.	Plug cal box connector into PCB with orange wire towards crystal.
PRETONE L.E.D. is blinking	Unit needs calibration.	Calibrate
Housing fails air seal test.	Gasket not seated correctly	Remove lens assembly and rotate 180 degrees. Reinstall.
	Leaking Lens Gasket	Replace housing.
	Leaking Stabilizing Grommet	Replace.
	Defective housing	Replace housing.
Halogen lamp does not light.	Low battery voltage.	Recharge or replace battery.
	Defective halogen lamp.	Replace lamp.
Handle does not charge.	Bent or broken charging contacts in charging well.	Re-shape contact(s) Replace Housing Assembly
Excessive battery drain.	Shorted lamp.	Replace Lamp.

Section 4:

Disassembly and Repair

4.1 Disassembly Procedure, AudioScope3

Caution: The battery and lamp become very hot during operation.
Allow ten minutes of cool-down time before opening unit.

Abstract: The Printed Circuit Board and power jack are easily removed from the handle housings. The spring steel charger well contacts on the handle are spring steel and will snap when attempting to spread them too far. The mini-transducer (speaker) and sound tube are easily removed from the board without removing the board from the handle housing. The rubber gasket that seals the sound tube to the AudioScope head is called a Stabilizing Grommet. This grommet can be changed if it leaks air. Air leaks can deteriorate the performance of the instrument. Air leaks are a result of rough handling and resultant broken seals in the housing halves, or bad gaskets around the lens and or the stabilizing grommet.

Lens gaskets are installed during assembly before right and left side cases are bonded together. Replacement is not covered in this manual.

4.1.1 Prepare the unit for disassembly or service

- ___ Turn the LOCKED/OPEN knob on the bottom of the AudioScope to OPEN (the two lines should meet together at the bottom). Use a flathead screwdriver or coin.
- ___ Slide the top of the housing backwards, exposing the battery and board.
- ___ Lift the battery out by pulling upwards on the positive end.
- ___ Remove the lamp by pressing the blue button on the board.

4.1.2 Speaker removal

- ___ Do not try to pull the sound tube out of the boot since the boot end of the sound tube is flared.
- ___ Gently push the speaker boot (containing the speaker) off of the metal spring clip.
- ___ Gently pull the speaker out of the boot.
- ___ Note the position of the red and black wires relative to the imprinting on the speaker and un-solder them (using T19102-2).

4.1.3 Speaker replacement

- ___ Solder red and black wires to new speaker in the order noted above (in step 4.1.3) .
- ___ Gently press the speaker into the speaker boot.

4.1 Disassembly Procedure, AudioScope3

(continued)

4.1.4 Stabilizing Grommet removal *(sound tube gasket near lamp)

- ___ Slide the speaker boot off of the clip and pull the sound tube out of the stabilizing grommet.
- ___ Peel the old grommet out of the ring at the end of the board.
- ___ Install new grommet by carefully pressing it into the ring.
- ___ Insert the sound tube into the stabilizing grommet and then slide the speaker boot (containing the speaker) onto the spring clip.
- ___ Adjust the height of the sound tube so that approximately 1/8" extends into the housing behind the lens. See Figure 2.5.4
- ___ Perform a leak check on the instrument after replacing stabilizing grommet.

4.1.5 Printed circuit board removal

- ___ Unscrew two screws at the positive terminal end of the circuit board.
- ___ Pull the board towards the battery compartment and carefully lift the board out.

4.1.6 Power jack removal

- ___ Unscrew jack ring nut with T-10912
- ___ Un-solder (using T19102-2) three connections on back of jack.
- ___ Remove jack from housing.

Reassembly

4.1.7 Install power jack

- ___ Put jack through hole in housing so that three tabs line up with components.
- ___ Restore connections by soldering (using T19102-2) three components to tabs on jack.

4.1.8 Place board into housing

- ___ Place the switch on the housing on the "off" position.
- ___ Place the switch mounted on the circuit board to the 40 dB position, toward the yellow LED.
- ___ Position the sound tube gasket into the hole in head of the instrument. The 5/16" round rubber ring will line up with the end of the fiber optic bundle.
- ___ Gently push the board back into its original position. The tab of the switch will engage the cavity of the switch button.

4.1 Disassembly Procedure, AudioScope3

(continued)

4.1.9 Prepare the unit for functional check and calibration.

- ___ Place a known good lamp into the unit.
- ___ Place a known good, charged battery into the unit.
- ___ Perform full functional check per A specifications
- ___ Check frequency and amplitude / Calibrate unit.

4.2 Disassembly Procedure, Charging Stand.

Abstract: The Charging Stand disassembles to three main components: the base plate, the holder, and the housing assembly. If the internal circuit board fails, replace the housing assembly. Bent charging contacts cannot be replaced since they are heat-staked into the housing assembly.

4.2.1 Prepare charger stand unit for disassembly.

- ___ Unplug charging transformer from mains.
- ___ **Remove specula.**

4.2.2 Base plate assembly removal.

- ___ Unscrew four screws holding the base plate assembly to the housing assembly.
- ___ Push the base out of the housing (if it sticks) with the handle of a screwdriver or small hammer.
- ___ Lift the holder (top portion of the charging stand) out of the housing.

4.2.3 Rubber feet.

- ___ Push old rubber feet out of base plate.
- ___ Push replacement feet into holes in base plate.

4.2.4 Reassemble.

- ___ Slide holder into housing assembly. Do not crush contacts.
- ___ Place base into housing assembly.
- ___ Attach base to housing assembly with four screws.

4.2.5 Test

- ___ Connect a known good charger to the Charging Stand jack.
- ___ Put a "known good" handle into the charging well.
- ___ Charging light will light if stand is functioning normally.

Section 5:

Drawings / Test Specifications

5.1 Drawings and Test Specifications

This section contains the following documents for service and calibration of AudioScopes.

Drawing#	Description	Size/# sheets
A02030	Repair Calibration Spec. for AudioScope II	B/1 of 1
A00277	Audiometer Handle Test Specifications	D/1 of 1
A00984	P.C.B. Test Spec AudioScope II	D/1 of 1
A00273	Electronics Module Test Specification	D/1 of 2
A00273	Electronics Module Test Specification	D/2 of 2
A00985	Audio Module III Test Spec	D/1 of 1
A01825	AudioScope III Sound Equipment Calibration and Setup	C/1 of 1
A00942	Charging Stand Electrical Test Spec.	A/1 of 1
230230	Audio II Schematic (PCB for <u>ASIC version</u>)	D/1 of 1
230215	PC Board Ass'y (for <u>ASIC version</u>)	D/1 of 1
236630	PCB Schematic (for <u>Microcontroller version</u>)	B

Parts catalog pages

230137-3	Nos. 23000, 23020, 23040 AudioScope	A/1 of 1
230237-1	No. 23300 AudioScope II and 3	A/1 of 1
711408-2	No. 71123 Charging Stand	A/1 of 1

THESE DRAWINGS AND SPECIFICATIONS ARE THE PROPERTY OF WELCH ALLYN, INC. AND SHALL NOT BE REPRODUCED, OR COPIED, OR USED AS A BASIS FOR MANUFACTURE OR SALE OF EQUIPMENT OR DEVICES WITHOUT WRITTEN PERMISSION.

REV	REVISION DESCRIPTION	ECN	DATE	APPROVAL
A	RELEASE TO PROD. ENG.	5-19006	5/5/89	

THE FOLLOWING MEASUREMENTS ARE TO BE PERFORMED PER A00965. IF THE MEASUREMENT IS NOT WITHIN THE SPECIFICATION LISTED BELOW, THEN THE INSTRUMENT IS TO BE READJUSTED FOR THAT PARAMETER. READJUSTMENT MAY BE MADE IN THE SAME HANDLE. IF THE INSTRUMENT CANNOT BE READJUSTED SUCH THAT THE NEW MEASUREMENT IS WITHIN SPECIFICATION, THEN IT SHALL BE REPAIRED OR THE PC BOARD SHALL BE REPLACED.

FREQUENCY: ± 3 DB, FOR MEASUREMENT PURPOSES, CANNOT BE READJUSTED.

SOUND LEVEL: ± 3 DB AT 500, 1000, AND 2000 HZ, ± 4 DB AT 4000 HZ, ± 3 DB AT PRETONE (1000 HZ).

THE FOLLOWING ADDITIONAL MEASUREMENTS ARE TO BE FOR ONE TONE ONLY. THE RESULTS SHOULD MATCH THOSE OF * TABLE 1, IF THE MEASUREMENT IS NOT WITHIN THE SPECIFICATION LISTED, THEN THE INSTRUMENT SHALL BE REPAIRED OR THE PC BOARD SHALL BE REPLACED.

* NOTE: MEASUREMENTS AND SPECIFICATIONS IN TABLE 1 ARE FOR THE 1000 HZ (SECOND PULSE) ONLY.

REMOVE AUDIOSCOPE BOARD FROM THE HANDLE AND INSERT IT INTO SPECIAL TEST FIXTURE. APPLY DC POWER AND HOOK OSCILLOSCOPE UP TO TEST FIXTURE.

MAKE THE FOLLOWING OSCILLOSCOPE SETTINGS:

CH. 1 - DC - 20 OR 50 MSEC
 POSITION KNOB - 11 O'CLOCK
 STORE MODE - NORMAL
 TIME/DIV - 2 SEC.
 COUPLING - HF REJ
 SOURCE - CH. 1

MAKE SURE THE GREEN LIGHT IN THE UNIT BEING TESTED IS ON. PRESS THE START BUTTON ON THE AUDIOSCOPE II BOARD AND RECORD ENTIRE SEQUENCE IN A STORAGE OSCILLOSCOPE.

YOU SHOULD NOW HAVE A TRACE SIMILAR TO THAT IN FIG. 1. SAVE THE TRACE AND INCREASE HORIZONTAL MAGNIFICATION BY 10. SET UP THE POSITIONING TO VIEW THE SECOND PULSE IN THE PULSE TRAIN (1000 HZ).

TO MEASURE THE RISE TIME MEASURE THE TIME (HORIZONTAL DISTANCE) BETWEEN POINTS INDICATED BY "A" AND "B" ON FIG. 2. THE TIME IN MILLISECONDS SHOULD BE WITHIN THE TOLERANCES LISTED IN TABLE 1.

TO MEASURE THE ON TIME MEASURE THE TIME BETWEEN THE POINTS INDICATED BY C AND D IN FIG. 2. THE TIME IN SECONDS SHOULD BE WITHIN THE TOLERANCES LISTED ON TABLE 1.

TO MEASURE THE OFF TIME POSITION THE DISPLAY, USING THE LEFT RIGHT POSITION KNOB, SO YOU CAN MEASURE THE TIME BETWEEN POINTS D AND E AS INDICATED ON FIG. 2. THE TIME IN SECONDS SHOULD BE WITHIN THE TOLERANCES LISTED ON TABLE 1.

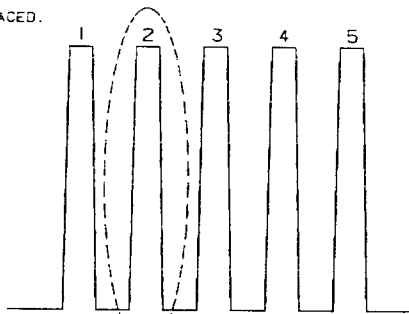

FIGURE 1

RISE TIME	60 mSec. ± 40 mSec.
ON TIME	1.5 Sec. $\pm .1$ Sec.
OFF TIME	1.75 Sec. $\pm .1$ Sec.

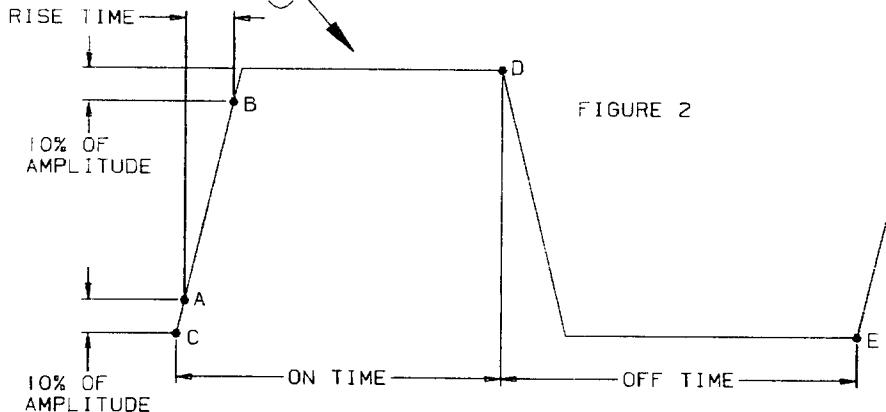

FIGURE 2

MATERIAL:

FINISH:

UNLESS OTHERWISE SPECIFIED DIMENSIONS ARE IN INCHES		
TOLERANCES ON:		
BASIC DIMENSION	. XX	. XXX
UP TO 6	$\pm .02$	$\pm .005$
ABOVE 6 TO 24	$\pm .03$	$\pm .010$
ABOVE 24	$\pm .06$	$\pm .015$
ANGLES: $\pm 1/2$ DEGREE		

DRAWN R. J. GAMBUTTA	DATE 5/5/89
CHECKED	
APPROVED	
REL. FOR PROCD.	
DO NOT SCALE	

WELCH ALLYN, INC. SKANEATELES FALLS, N.Y. U.S.A.	
TITLE: REPAIR RECALIBRATION SPEC. FOR AUDIOSCOPE II	
CODE IDENT. B	DRAWING NO. A02030
SCALE N/A	REV. A
SHEET 1 OF 1	

MAY 24 1989

FIG 1 L.E.D. TEST

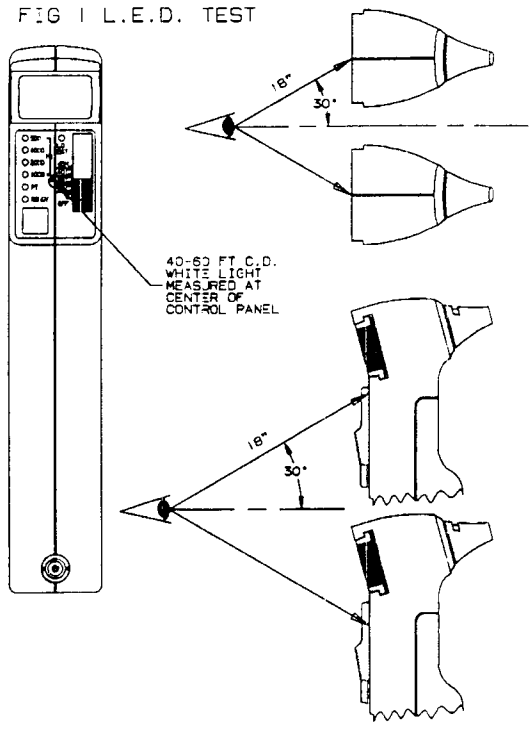
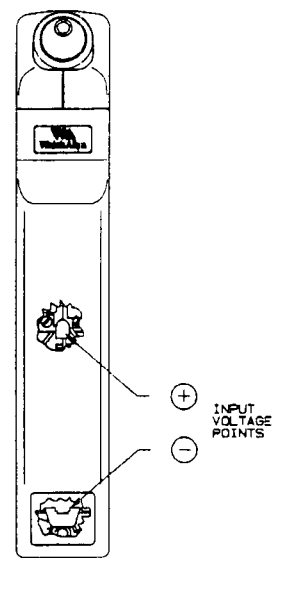

FIG 2 POWER CONNECTIONS



AUDIOMETER HANDLE TEST SPECIFICATION

AT THE COMPLETION OF ASSEMBLY, EACH HANDLE SHALL BE SUBJECTED TO ALL TESTS LISTED BELOW. NO HANDLE SHALL BE SHIPPED NOR STOCKED WHICH DOES NOT MEET ALL TEST CRITERIA.

11. START BUTTON: THE START BUTTON SHALL ACTIVATE WITH A FORCE OF 0.5 - 1.0 LBS.
12. ON/OFF SWITCH: THE SLIDE SWITCH SHALL OPERATE WITH A LONGITUDINAL FORCE OF 0.5-4.0 LBS (SLIDING "ON") AND 1.0-5.0 LBS (SLIDING "OFF").
3. L.E.D.'S: ALL L.E.D.'S SHALL BE OF SUFFICIENT BRIGHTNESS TO BE BE VISIBLE UNDER CONDITIONS OF NORMAL AMBIENT ILLUMINATION AND VIEWING ANGLE. ANY UNITS THAT ARE QUESTIONABLE MAY BE TESTED BY VIEWING 18" AWAY AT A 30° CONICAL ANGLE WITH 40-60 FT CANDLES OF WHITE LIGHT ILLUMINATION ON THE CONTROL PANEL. (SEE FIGURE 1) THE UNIT IS ACCEPTABLE IF ALL L.E.D.'S ARE VISIBLE AT ALL ANGLES.
4. RATTLE: THERE SHALL BE NO PERCEIVABLE NOISE GENERATED WHEN THE HANDLE IS SHAKEN.
- * 5. SOUND LEVEL: THE SOUND LEVEL OF ALL TONES SHALL BE RECHECKED PER THE SPECIFICATIONS OF A00273 (AUDIOSCOPE I) OR A00985 (AUDIOSCOPE II) (ELECTRONICS MODULE TEST SPECIFICATION) THE MEASURED LEVEL SHALL BE WITHIN ±1.5dB, ±2.0 dB @ 4000 Hz (AUDIOSCOPE I) OR ±1.0 dB, ±1.5 dB @ 4000 AND 500 Hz (AUDIOSCOPE II) OF THE DESIRED LEVELS. THE SOUND LEVEL SHALL NOT BE READJUSTED TO MEET THIS SPECIFICATION.
7. COVER: THE COVER SHALL SLIDE ON AND OFF AND LOCK IN POSITION WITHOUT UNQUE FORCE.
8. PNEUMATIC SEAL: THE INSTRUMENT SHALL BE CONNECTED TO AN AIR SOURCE WHICH GENERATES 200CC/MIN. FLOW UNOCCLUDED, AND 500MM H₂O PRESSURE WHEN OCCLUDED. THE SEAL IS ACCEPTABLE IF THE PRESSURE DEVELOPED EXCEEDS 254MM H₂O WITH THE INSTRUMENT CONNECTED. (SEE FIGURE 4). THE INCLUDED AIR VOLUME OF THE TEST SYSTEM SHOULD BE MINIMIZED.
9. CHARGE: THE UNIT SHALL NOT OPERATE WHEN THE CHARGER IS CONNECTED WITH AN INPUT OF 120V ±2V, 60 Hz TO A MODEL 71040 CHARGER. THE CHARGING CURRENT DELIVERED TO THE HANDLE SHOULD BE 75-100 mA (AS MEASURED ON A D.C. AVERAGING METER). (SEE FIGURE 5.)

FIG 4 PNEUMATIC SEAL

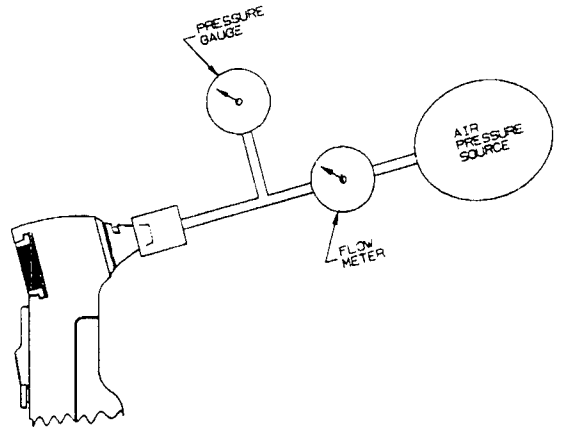
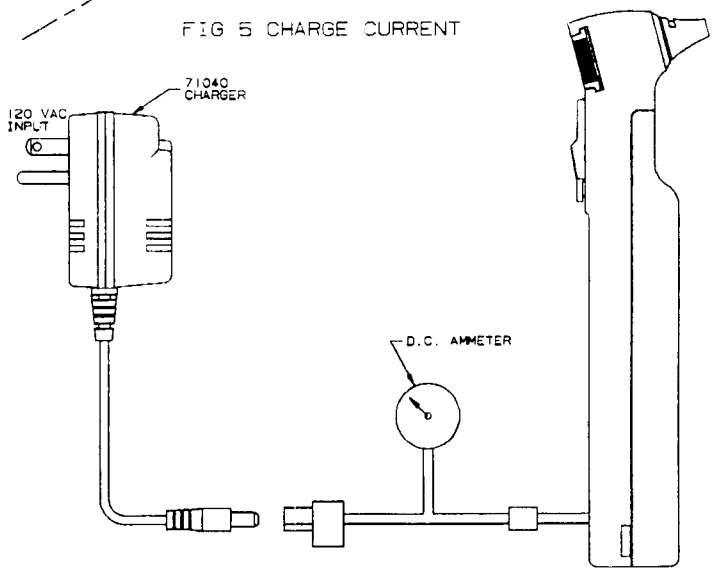

FIG 5 CHARGE CURRENT



- * 10. LAMP EJECTOR: SEE TEST SPEC A00273 (AUDIOSCOPE I) OR A00985 (AUDIOSCOPE II).
- * 11. TRAINED LISTENER: SEE TEST SPEC A00273 (AUDIOSCOPE I) OR A00985 (AUDIOSCOPE II).

* THESE TESTS ARE ONLY REQUIRED IF THE ELECTRONIC MODULE WAS NOT CALIBRATED IN THIS PARTICULAR HANDLE, OR IF THE MODULE WAS REMOVED FROM THE HANDLE.

† EXACT MEASUREMENTS ARE NOT REQUIRED FOR 100% INSPECTION.

REV 2 A 1000

SUPERSEDES DWG DATED 12-20-82

MATERIAL:	PART NO.		DESCRIPTION	
	71040	DATE: 1-17-83	Walsh & Ryan	REVISIONS: 1-17-83
FINISH:	DESIGNED	DATE: 1-20-83	TITLE: AUDIOMETER HANDLE TEST SPECIFICATIONS	
UNLESS OTHERWISE SPECIFIED DIMENSIONS ARE IN INCHES AND DECIMAL PLACES TOLERANCES ARE: XX ± .02 ANGLES: 41/2° HOLE ± .002 REMOVE BURRS & SHARP EDGES EXTERNAL TAPS: CLASS - 2A INTERNAL TAPS: CLASS - 3B	APPROVED: JWH	DATE: 1-20-83	CHECKED: []	DRAWING NO. A00277 REV J
	REL. TO PROD. DES.	DATE: 2-7-83	SCALE: 1:1	DO NOT SCALE 1 OF 1

FIGURE 1 TIMING DIAGRAM
INDIVIDUAL TONE AND SPACE ERRORS
ARE NON-CUMULATIVE

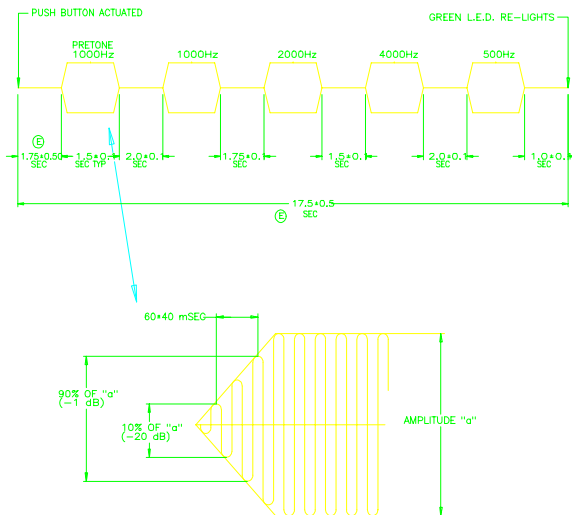

NOTES:

① REFER TO AUDIOSCOPE II SCHEMATIC (DWG 230230) FOR ALL TEST POINT LOCATIONS. FOR THE PURPOSES OF THIS TEST, A JUMPER BETWEEN TEST POINT NO. 1 AND GROUND (NEGATIVE INPUT TERMINAL) MAY BE USED TO "LATCH" EACH TONE "ON" FOR PURPOSES OF MEASUREMENT.

- 3.50±0.01 V.D.C. IS APPLIED TO THE INPUT VOLTAGE TERMINALS (SEE FIGURE 2).
- AN AUDIO AMPLIFIER AND SPEAKER ARE CONNECTED TO THE OUTPUT TERMINALS (TWISTED LEADS).

② THE FIVE AMPLITUDES ARE SET TO THE FOLLOWING VOLTAGES:

FREQ (Hz)	OUTPUT @ T.P.2 (mV R.M.S.)	TOLERANCE (mV R.M.S.)
PT	400	±25
1000	40	±5
2000	185	±25
4000	110	±20
500	50	±5

- THE SLIDE SWITCH (S1) IS TURNED "ON" TO THE 40 dB LEVEL SETTING. THIS IS THE SWITCH POSITION CLOSEST TO THE YELLOW L.E.D.
- THE GREEN L.E.D. SHOULD LIGHT.
- THE START BUTTON (S2) IS PUSHED.

③ THE FIVE RED L.E.D.'S SHOULD ILLUMINATE SEQUENTIALLY. THE DURATION OF THE TONES SHOULD BE APPROXIMATELY 1.5 SEC. THE INTERVAL BETWEEN TONES IS VARIED AS SPECIFIED ON FIGURE 1. AN AUDIO TONE SHOULD BE HEARD WHEN EACH L.E.D. LIGHTS (THE TONES MAY BE OF VARIED AMPLITUDE AND/OR FREQUENCY). AT THE END OF THE SEQUENCE, THE GREEN L.E.D. SHOULD RELIGHT. THE TIME BETWEEN ACTUATION OF THE PUSHBUTTON AND RELIGHTING OF THE GREEN L.E.D. SHALL BE AS SHOWN IN FIGURE 1. INPUT CURRENT SHALL NOT EXCEED 30 mA DURING ANY PORTION OF THE CYCLE.

④ THE INPUT VOLTAGE IS DECREASED TO 3.1 V. THE GREEN L.E.D. SHOULD GO OUT AND THE YELLOW L.E.D. SHOULD LIGHT. THE INPUT SHOULD THEN BE INCREASED AND THE GREEN L.E.D. SHOULD RELIGHT AT 3.2 TO 3.55 V. ONLY ONE L.E.D. SHOULD BE ON AT A TIME. NEITHER L.E.D. SHOULD FLICKER.

⑤ LATCH-UP

A. THE PUSHBUTTON SWITCH SHALL BE DEPRESSED MOMENTARILY. THE GREEN L.E.D. SHALL GO OUT AND THE FIVE RED L.E.D.'S SHALL ILLUMINATE SEQUENTIALLY.

B. WHEN EACH RED L.E.D. LIGHTS IT SHALL BE "LATCHED ON" BY CONNECTING TEST POINT NO. 1 TO GROUND (NEGATIVE INPUT TERMINAL). IT MAY BE "UNLATCHED" BY DISCONNECTING THE TEST POINT FROM GROUND.

C. FOR EACH L.E.D. THE FOLLOWING MEASUREMENTS AND ADJUSTMENTS SHALL BE MADE:

- FREQUENCY - THE OUTPUT FREQUENCY SHALL BE MEASURED BY THE ELECTRICAL SIGNAL BETWEEN TEST POINT NO. 2 AND GROUND. THE FREQUENCY INDICATION SHALL BE WITHIN ±1.0% OF THAT SHOWN BELOW. THE FREQUENCIES SHALL BE STABLE WITHIN ±1 Hz DURING THE FIRST 2 SEC AFTER SELECTION.

TONE NO.	FREQ (Hz)
1	1000
2	1000
3	2000
4	4000
5	500

- DISTORTION - THE TOTAL HARMONIC DISTORTION FOR EACH TONE (EXCLUDING PRETONE (PT)) SHALL BE MEASURED FROM TEST POINT NO. 2 TO GROUND. THE T.H.D. SHALL NOT EXCEED 3.0%. A 30 KHz LOW PASS FILTER SHOULD BE USED WHEN MAKING THIS MEASUREMENT.

⑥ 10. NORMAL CYCLE

THE GREEN L.E.D. SHOULD RELIGHT AFTER THE PRECEDING TEST SEQUENCE. THE PUSHBUTTON SWITCH SHALL BE DEPRESSED AGAIN, MOMENTARILY, AND THE FOLLOWING PARAMETERS CHECKED DURING THE NORMAL OPERATION OF THE MODULE:

- RISE/FALL TIME - EACH TONE SHALL RISE AND FALL IN AMPLITUDE IN A GRADUAL MANNER. THE RISE AND FALL TIMES SHALL BE 60x40 USEC AS MEASURED BY THE DIFFERENCE BETWEEN THE 10% AND 90% POINTS IN VOLTAGE AT TEST POINT NO. 2 (SEE FIGURE 1). THE ACTUAL RISE/FALL TIME NEED ONLY BE VERIFIED ON ONE TONE.

B. TIMING - THE DURATION OF TONES AND PAUSE BETWEEN THEM AS SHOWN IN FIGURE 1 SHALL BE CHECKED. THIS CAN BE MEASURED BY THE ELECTRICAL SIGNAL BETWEEN TEST POINT NO. 2 AND GROUND.

AN ALTERNATE WAY OF CHECKING THE TIMING IS TO PROBE PIN 14 OF THE I.C. THIS WILL BE A DIGITAL SIGNAL WITH THE DURATION OF THE HIGH PULSE BEING THE TONE "ON" TIME AND THE DURATION OF THE LOW PULSE BEING THE "OFF" TIME.

⑥ 11. SECOND CYCLE

THE MODULE SHALL BE PUT THROUGH ANOTHER CYCLE (BY ACTUATING THE PUSHBUTTON SWITCH) TO TEST THE RESTART FUNCTION.

RESTART - AT ANY POINT DURING THE CYCLE, THE PUSHBUTTON SWITCH IS DEPRESSED. ANY L.E.D. THAT WAS LIT SHOULD GO OUT AND THE NORMAL SEQUENCING SHOULD START OVER.

FIGURE 2
SOLDER SIDE OF
P.C.B SHOWN

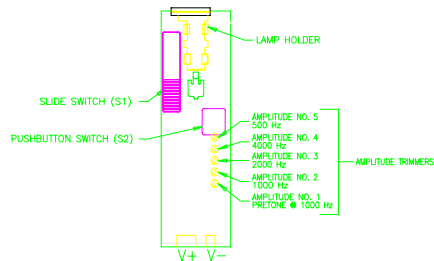

REV	REVISION	DESCRIPTION	ECN	INIT	DATE	APPROVAL
A	REL TO PROD ENG		2	112	9/30/86	RRB
B	REV'D LAMP & LAMP ELECTOR; ADD NOTE		1	118	10/16/86	RRB
C	REV'D NOTES 3, 8 & 12		1	133	9/4/87	JJS
D	REV'D NOTES 7,9,10,11 & 12		1	188	9/30/87	JJS
E	REV'D NOTES 3,7,8,10 & 11; DELETED NOTE 12; 1,75±0.50 WAS 1,25±0.50; 1,75±0.5 WAS 1,7,25±0.5		1	199	12/8/87	JJS
F	REV'D NOTE 8		1	110	5/3/88	JJS
G	REV'D NOTES 3 & 8		1	163	7/14/88	JJS
H	REV'D NOTE 8		1	188	12/8/88	JJS
J	REV'D NOTES 3 & 9		1	272	7-7-94	OCF

MATERIAL:		FINISH:		QTY	QTY	QTY	ITEM	PART NUMBER		DESCRIPTION	
	UNLESS OTHERWISE SPECIFIED:			504	503	502	SYMBOL				
REF. DIMS	METRIC DIMENSIONS (WHEN USED) ARE IN ()	TOLERANCES ON:		DRAWN		DATE		LIST OF MATERIAL			
	DIMENSIONS INCLUDE PLATING.	BASE DIMENSION	.XX	.XXX	C. WOLNOWNICZ		9/10/86	WELCH ALLYN, INC.			
	REMOVE BURRS & SHARP EDGES.	UP TO 6	±.02	±.005	J SAROFEEN		9/12/86	SKANEATELES FALLS, N.Y. U.S.A.			
	THREADS ARE UNIFIED SERIES AND INCLUDE PLATING.	ABOVE 6 TO 24	±.03	±.010	APPROVED		R BLACK	9/12/86	TITLE: P.C.B. TEST SPEC AUDIOSCOPE II		
EXTERNAL THIS = CLASS-2 A INTERNAL THIS = CLASS-2 B	ABOVE 24	±.06	±.015	CODE		DRAWING NO.		A00984			
GROUP OR PART	ANGLES - 1/2 DEGREE	REL FOR PROD.		SCALE		SHEET		OF 1			
	APPLICATION	DO NOT SCALE		B CAMPAGNA		10/3/86					

THESE DRAWINGS AND SPECIFICATIONS ARE THE PROPERTY OF WELCH ALLYN, INC. AND SHALL NOT BE REPRODUCED, COPIED, OR USED AS A BASIS FOR MANUFACTURE OR SALE OF EQUIPMENT OR SERVICES WITHOUT WRITTEN PERMISSION.

AA0273

ELECTRONICS MODULE TEST SPECIFICATION

AT THE COMPLETION OF ASSEMBLY, EACH MODULE SHALL BE SUBJECTED TO THE TESTS LISTED BELOW. NO MODULE SHALL BE SHIPPED FOR STORAGE WHICH DOES NOT PASS ALL TESTS LISTED. ...

DURING THE SOUND LEVEL MEASUREMENT TEST, THE MODULE MUST BE SECURED TO A 230073-501 HOUSING ASSEMBLY AS SHOWN IN 230008-501 (AUDIOMETER ASSY). LENS HOLDER ASSY 230055-501 IS ALSO INDICATED.

START-UP

1. THE SLIDE SWITCH IS MOVED TO THE POSITION CLOSEST TO THE L.E.D.'S. THE GREEN L.E.D. ONLY, SHALL BECOME IMMEDIATELY ILLUMINATED.

QUICK CHECK

THIS TEST IS OPTIONAL. IT MAY BE USED TO RAPIDLY ASSESS THE FUNCTIONALITY OF A MODULE. THE SOUND LEVEL METER MICROPHONE OUTPUT IS AMPLIFIED AND DRIVES A LOUSPEAKER. THE PUSHBUTTON SWITCH IS ACTUATED. A SERIES OF FOUR TONES SHOULD BE HEARD WHICH COINCIDE WITH SEQUENTIAL LIGHTS OF THE FOUR RED L.E.D.'S.

LAMP-ON

1. THE PUSHBUTTON SWITCH SHALL BE DEPRESSED MOMENTARILY. THE GREEN L.E.D. SHALL GO OUT AND THE FOUR RED L.E.D.'S SHALL ILLUMINATE SEQUENTIALLY.

2. WHEN EACH RED L.E.D. LIGHTS, IT SHALL BE "LATCHED ON" BY CONTACTING TEST POINT NO. 1 TO GROUND (NEGATIVE SIDE OF BATTERY). IT MAY BE "UNLATCHED" BY DISCONNECTING THE TEST POINT FROM GROUND.

3. FOR EACH L.E.D., THE FOLLOWING MEASUREMENTS AND ADJUSTMENTS SHALL BE MADE: a) FREQUENCY - THE OUTPUT FREQUENCY SHALL BE MEASURED BY THE ELECTRICAL SIGNAL BETWEEN TEST POINT NO. 2 AND GROUND. THE FREQUENCY INDICATION SHALL BE WITHIN +/- 0.5% OF THAT SHOWN BELOW.

Table with columns: TONE NO., FREQ. (Hz). Rows: 1 (500), 2 (1000), 3 (2000), 4 (4000).

b) CALIBRATION - FOR THIS TEST, A FULLY CHARGED MOD. 72300 BATTERY MUST BE ASSEMBLED TO THE HANDLE (AS SHOWN IN DWG. 230002-501 (AUDIOMETER ASSY)) AND USED TO POWER THE MODULE. TEST POINTS 3 AND 4 SHALL BE CONNECTED TOGETHER ELECTRICALLY FOR THIS TEST. IN ORDER TO VERIFY MAXIMUM AMPLITUDE, THE LAMP SHALL BE IN THE LAMP HOLDER AND ILLUMINATED. DURING THE TEST, THE TONE LEVEL INDICATION FOR EACH TONE SHALL BE MEASURED FROM TEST POINT NO. 2 TO GROUND. THE C.H.D. SHALL NOT EXCEED 3.0 db.

c) SOUND LEVEL - THE SOUND LEVEL MEASURED AT THE EAR STRUCTURE, USING THE APPROPRIATE OCTAVE BAND FILTER, SHALL BE ADJUSTED TO THE VALUES SHOWN BY USING THE APPROPRIATE TRIMMER (SEE FIG. 3). THE ADJUSTMENT SHALL YIELD A LEVEL INDICATION WITHIN +/- 0.20 db OF THE DESIRED. THE LEVEL SHALL BE STABLE WITHIN +/- 0.1 db DURING THE 2 SEC. PERIOD FOLLOWING THE INITIAL RISE.

NORMAL CYCLE

1. IN KEEP L.E.D. SHOULD RELIGHT AFTER THE ABOVE TEST SEQUENCE. THE PUSHBUTTON SWITCH SHALL BE DEPRESSED AGAIN. IMMEDIATELY AFTER THE FOLLOWING PARAMETERS CHECKED OVER THE NORMAL OPERATION OF THE MODULE:

- a. CURRENT DRAIN - THE CURRENT DRAIN FROM THE 3.5 V.D.C. SUPPLY SHALL NOT EXCEED 100 MA DURING ANY PORTION OF THE CYCLE. b. TONE SHUT-OFF - THE SOUND PRESSURE LEVEL MEASURED AT THE EAR STRUCTURE SHALL DROP AT LEAST 15 db. AFTER EACH TONE (USING OCTAVE BAND FILTER OF PRECEDING TONE).

SECOND CYCLE

THE MODULE SHALL BE PUT THROUGH ANOTHER CYCLE (BY ACTUATING THE PUSHBUTTON SWITCH) TO TEST THE RESTART AND LOW BATTERY FUNCTIONS.

- * 1. INSTANT - AT ANY POINT DURING THE CYCLE, THE PUSHBUTTON SWITCH IS DEPRESSED. ANY L.E.D. THAT WAS LIT SHOULD GO OUT AND THE NORMAL SEQUENCING SHOULD START OVER. * 2. LOW BATTERY - THE INPUT VOLTAGE IS GRADUALLY DECREASED. THE GREEN L.E.D. SHOULD GO OUT AND THE YELLOW L.E.D. SHOULD LIGHT AT A VOLTAJE BETWEEN 3 TO AND 3.40V.

ONE L.E.D. SHOULD BE "ON" AT A TIME. NEITHER L.E.D. SHOULD FLICKER.

TRAINED LISTENER

- a.) INTENSITY OF TONES b.) QUALITY OF TONES c.) STABILITY OF TONES d.) EXTRANEOUS NOISE BETWEEN TONES (ESPECIALLY HIGH PITCHED SQUEALS OR STATIC).

THEY MAY REJECT INSTRUMENTS THAT VARY SIGNIFICANTLY FROM AN INSTRUMENT OF KNOWN CALIBRATION AND QUALITY.

LAMP EJECTOR

WHILE THE MODULE IS IN A 230000-501 AUDIOMETER ASSY, A 05200 LAMP SHALL BE INSERTED INTO THE LAMP HOLDER. THE LAMP SHALL CENTER ON THE FIBER OPTIC BUNDLE AND BECOME ILLUMINATED. THE LAMP EJECTOR IS DEPRESSED. THIS SHALL EJECT THE LAMP TO A POSITION WHERE IT IS EASILY ACCESSIBLE BY HAND.

BURN IN

AT COMPLETION OF ASSEMBLY AND BEFORE FINAL TESTING, ALL UNITS WILL BE POWERED UP AT THE NOMINAL OPERATING VOLTAGE. UNITS SHALL BE OPERATIONALLY CYCLED CONTINUOUSLY DURING THE BURN IN PERIOD. THE BURN IN PERIOD WILL BE A MINIMUM OF 24 HOURS. THIS PERIOD DOES NOT HAVE TO BE CONTINUOUS.

HOUSING ASSY

THE HOUSING ASSY (230073-501) USED FOR INITIAL CALIBRATION SHALL CONTAIN A SPECIALLY SELECTED FIBER-SPECULUM ASSY (200005-502) WITH A CONE-SEATING DIMENSION OF 0.240 +/- 0.005 AND GRIND LENGTH OF 1.655 +/- 0.05

Revision table with columns: REV, REV'S ON, DESCRIPTION, E.I. INCHES, DATE, APPROVAL. Rows 1-7.

Table with columns: REV, REV'S ON, DESCRIPTION, E.I. INCHES, DATE, APPROVAL. Row 8.

Table with columns: REV, REV'S ON, DESCRIPTION, E.I. INCHES, DATE, APPROVAL. Row 9.

Table with columns: REV, REV'S ON, DESCRIPTION, E.I. INCHES, DATE, APPROVAL. Row 10.

Table with columns: REV, REV'S ON, DESCRIPTION, E.I. INCHES, DATE, APPROVAL. Row 11.

Table with columns: REV, REV'S ON, DESCRIPTION, E.I. INCHES, DATE, APPROVAL. Row 12.

Table with columns: REV, REV'S ON, DESCRIPTION, E.I. INCHES, DATE, APPROVAL. Row 13.

Table with columns: REV, REV'S ON, DESCRIPTION, E.I. INCHES, DATE, APPROVAL. Row 14.

Table with columns: REV, REV'S ON, DESCRIPTION, E.I. INCHES, DATE, APPROVAL. Row 15.

Table with columns: REV, REV'S ON, DESCRIPTION, E.I. INCHES, DATE, APPROVAL. Row 16.

Table with columns: REV, REV'S ON, DESCRIPTION, E.I. INCHES, DATE, APPROVAL. Row 17.

Table with columns: REV, REV'S ON, DESCRIPTION, E.I. INCHES, DATE, APPROVAL. Row 18.

Table with columns: REV, REV'S ON, DESCRIPTION, E.I. INCHES, DATE, APPROVAL. Row 19.

Table with columns: REV, REV'S ON, DESCRIPTION, E.I. INCHES, DATE, APPROVAL. Row 20.

Table with columns: REV, REV'S ON, DESCRIPTION, E.I. INCHES, DATE, APPROVAL. Row 21.

Table with columns: REV, REV'S ON, DESCRIPTION, E.I. INCHES, DATE, APPROVAL. Row 22.

Table with columns: REV, REV'S ON, DESCRIPTION, E.I. INCHES, DATE, APPROVAL. Row 23.

Table with columns: REV, REV'S ON, DESCRIPTION, E.I. INCHES, DATE, APPROVAL. Row 24.

Table with columns: REV, REV'S ON, DESCRIPTION, E.I. INCHES, DATE, APPROVAL. Row 25.

Table with columns: REV, REV'S ON, DESCRIPTION, E.I. INCHES, DATE, APPROVAL. Row 26.

Table with columns: REV, REV'S ON, DESCRIPTION, E.I. INCHES, DATE, APPROVAL. Row 27.

Table with columns: REV, REV'S ON, DESCRIPTION, E.I. INCHES, DATE, APPROVAL. Row 28.

Table with columns: REV, REV'S ON, DESCRIPTION, E.I. INCHES, DATE, APPROVAL. Row 29.

Table with columns: REV, REV'S ON, DESCRIPTION, E.I. INCHES, DATE, APPROVAL. Row 30.

Table with columns: REV, REV'S ON, DESCRIPTION, E.I. INCHES, DATE, APPROVAL. Row 31.

Table with columns: REV, REV'S ON, DESCRIPTION, E.I. INCHES, DATE, APPROVAL. Row 32.

Engineering drawing header including MATERIAL, FINISH, DIMENSIONS, TOLERANCES, PART NUMBER, LIST OF MATERIAL, and DRAWING INFORMATION (DRAWN, CHECKED, DATE, TITLE, CODE, SCALE, SHEET 2 OF 2).

FIGURE 1 TEST SET-UP

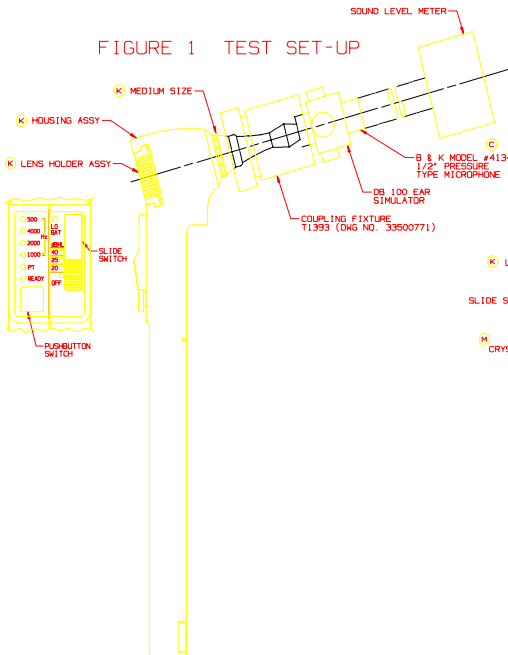

FIGURE 2

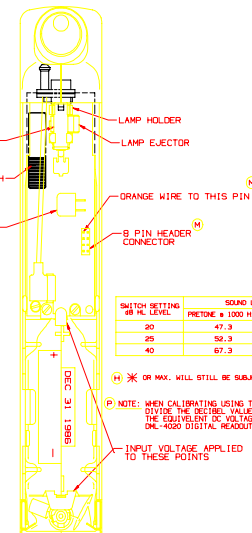

FIGURE 3 TIMING DIAGRAM (REF)
INDIVIDUAL TONE AND SPACE ERRORS
ARE NON-CUMULATIVE

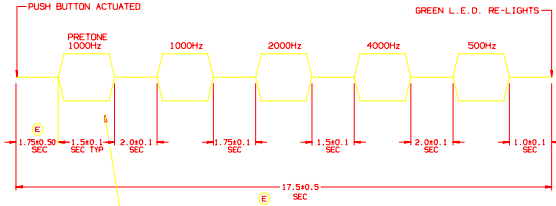

FIGURE 4 ACCEPTABLE LEVELS
FOR QC PURPOSES

SWITCH SETTING dB HL LEVEL	SOUND LEVEL dB RE 20µPa			
	PRETONE	1000 Hz	2000 Hz	500 Hz
20	46.3-48.3	26.3-28.3	31.2-34.2	32.0-35.0
25	51.3-53.3	31.3-33.3	36.2-39.2	37.0-40.0
40	66.3-68.3	46.3-48.3	51.2-54.2	52.0-55.0

NOTES:
AT THE COMPLETION OF ASSY, EACH MODULE SHALL BE SUBJECTED TO THE TESTS BELOW. THE TONE CALIBRATION PROCEDURE MUST BE DONE PRIOR TO ANY OTHER TEST. NO MODULE SHALL BE SHIPPED OR STOCKED WHICH DOES NOT PASS ALL TEST CRITERIA. TESTING SHALL BE IMMEDIATELY DISCONTINUED ON ANY MODULE THAT FAILS A TEST OR CANNOT BE ADJUSTED TO AN ACCEPTABLE VALUE. ALL TESTS INVOLVING SOUND LEVEL MEASUREMENT SHALL BE MADE IN AN AMBIENT SOUND LEVEL AT LEAST 10 dB BELOW THE DESIRED LEVEL BEING MEASURED (dB SPL REL TO 20µPa WITH APPROPRIATE OCTAVE FILTER).

DURING THE SOUND LEVEL MEASUREMENT TEST, THE MODULE MUST BE SECURED TO A HOUSING ASSEMBLY AS SHOWN IN 23301 AUDIOSCOPE 11 ASSEMBLY. THE LENS HOLDER ASSEMBLY IS ALSO ADDED.
THE SOUND MEASUREMENT EQUIPMENT SHOULD BE SET UP PER W.A. SPECIFICATIONS. A CHARGED BATTERY OR AN EXTERNAL POWER SOURCE OF 3.50±0.10 V.D.C. SHALL BE APPLIED TO THE INPUT TERMINALS OF THE MODULE. THE HOUSING ASSY SHALL BE COUPLED TO AN ENCLOSED EAR SIMULATOR (PDS ANSI STD NO. S3-25-1978) MAY BE PURCHASED FROM INDUSTRIAL RESEARCH PRODUCTS, INC. PART NO. 09100) VIA A WELCH ALLYN MEDIUM SIZE SOFT TIP SPECULA AND NO. 11293 COUPLING FIXTURE (SEE FIGURE 1). CARE MUST BE TAKEN TO PROVIDE AN ACOUSTIC SEAL BETWEEN ALL COMPONENTS. THE LAMP SHALL BE DISCONNECTED BY DEPRESSING THE LAMP EJECTOR BUTTON.

START UP
1. THE SLIDE SWITCH IS MOVED TO THE 25 dB POSITION; IF THE PCB HAS BEEN CALIBRATED THEN, THE GREEN L.E.D. SHALL BECOME IMMEDIATELY ILLUMINATED. IF THE PCB HAS NOT BEEN CALIBRATED THEN THE PRETONE L.E.D. WILL FLASH. THE TONE CALIBRATION PROCEDURE MUST BE DONE PRIOR TO ANY OTHER TEST.

QUICK CHECK
THIS TEST IS OPTIONAL. IT MAY BE USED TO RAPIDLY ASSESS THE OPERATION OF A MODULE. THE SOUND LEVEL METER MICROPHONE OUTPUT IS AMPLIFIED AND DRIVES A LOUD-SPEAKER. THE PUSHBUTTON SWITCH IS ACTUATED. A SERIES OF FIVE TONES SHOULD BE HEARD WHICH COINCIDE WITH SEQUENTIAL LIGHTING OF THE FIVE ORANGE L.E.D.'S. THE GREEN L.E.D. SHOULD RELIGHT AT THE END OF THE CYCLE.

TONE CALIBRATION
ATTACH THE T13975 AUDIOSCOPE CALIBRATION BOX TO THE B PIN HEADER CONNECTOR ON THE HANDLE'S END. THE ORANGE WIRE OF THE CAL BOX CONNECTOR SHOULD FACE THE END NEAREST THE CRYSTAL.
ATTACH THE MICROPHONE AS SHOWN IN FIG. 1. SLIDE THE SWITCH TO THE 25dBm POSITION. PLACE THE RANGE/CAL SWITCH ON THE CAL BOX TO THE CAL POSITION. THE GREEN READY LIGHT SHOULD FLASH AND THE ORANGE (PT) PRETONE LIGHT SHOULD BE ON. USING THE 1000Hz TONE ON THE BAK, ADJUST THE PRETONE LEVEL TO THE VALUE SHOWN IN TABLE 4. BY USING THE UP AND DOWN BUTTONS ON THE CAL BOX, THE LEVEL WILL CHANGE IN INCREMENTS EACH TIME THE BUTTONS ARE DEPRESSED. IF THE CENTER OF THE RANGE IS NOT ATTAINABLE SELECT A POINT TOWARDS THE UPPER HALF OF THE RANGE.
AFTER THE PROPER LEVEL IS SET, DEPRESS THE SAVE & INCREMENT BUTTON ON THE CAL BOX AND THE HANDLE WILL MOVE TO THE NEXT TONE TO BE ADJUSTED. REPEAT THIS SEQUENCE FOR ALL THE REMAINING FREQUENCIES REMEMBERING TO SELECT THE CORRECT FILTER ON THE BAK.
IT IS IMPORTANT TO SAVE AND INCREMENT AFTER THE 500Hz LEVEL BEFORE CHANGING THE dB LEVEL.

NOTE: ONCE THE PROPER ADJUSTMENT HAS BEEN MADE FOR ALL FREQUENCIES, THEN MOVE THE SWITCH TO THE 20 dB SETTING AND VERIFY THAT THE PROPER SOUND LEVELS FOR THAT SETTING ARE ACHIEVED WITHIN THE LIMITS SPECIFIED IN THE TABLE IN FIGURE 4. REPEAT THIS STEP FOR THE +40 dB SWITCH SETTING.

NORMAL CYCLE
THE GREEN L.E.D. SHOULD RELIGHT AFTER THE ABOVE TEST SEQUENCE. THE PUSHBUTTON SWITCH SHALL BE DEPRESSED AGAIN, MOMENTARILY, AND THE FOLLOWING PARAMETERS CHECKED: THE NORMAL OPERATION OF THE UNIT.
1. CURRENT DRAIN - THE CURRENT DRAIN FROM THE 3.5 V.D.C. SUPPLY SHALL NOT EXCEED 42 mA DURING ANY PORTION OF THE CYCLE.

NORMAL CYCLE - CONT.
2. TONE SHUT OFF - THE SOUND PRESSURE LEVEL MEASURED AT THE EAR SIMULATOR SHALL DROP AT LEAST 15 dB AFTER EACH TONE (USING OCTAVE BAND FILTER OR PRECEDING TONE).

AUDIBLE TONE TEST
AS A FINAL TEST, A PERSON USING AN AMPLIFIER AND HEADPHONES SHALL LISTEN TO THE INSTRUMENT IN A QUIET ROOM. (ROOM SOUND LEVELS AT LEAST 10 dB BELOW THE TONE LEVELS AT EACH OCTAVE BAND.) THE PERSON SHALL LISTEN FOR THE FOLLOWING:

- A. START/STOP OF TONES
- B. EXTRANEIOUS NOISE BETWEEN TONES (ESPECIALLY HIGH PITCHED SQUEALS OR STATIC)

THE PERSON MAY REJECT INSTRUMENTS THAT VARY SIGNIFICANTLY FROM AN INSTRUMENT OF KNOWN CALIBRATION AND QUALITY. THIS TEST IS TO BE REPEATED FOR ALL THREE SWITCH SETTINGS. INSTRUMENT SETTINGS FOR THIS TEST ON DWG 40185.

LAMP EJECTOR
WHILE THE MODULE IS IN A 23301 AUDIOSCOPE 111, A LAMP SHALL BE INSERTED INTO THE LAMP HOLDER. THE LAMP SHALL CENTER ON THE FIBER OPTIC BUNDLE AND BECOME ILLUMINATED. THE LAMP EJECTOR IS DEPRESSED. THIS SHALL EJECT THE LAMP TO A POSITION WHERE IT IS EASILY ACCESSIBLE BY HAND.

SOUND LEVEL COMPENSATION FOR CALIBRATION: (REF)

THE TABLE ABOVE SHOWS ACTUAL SOUND PRESSURE LEVELS REQUIRED FOR ACCURATE CALIBRATION OF WELCH ALLYN AUDIOSCOPIES. FOR BACKGROUND INFORMATION SEE ARTICLE "REFERENCE THRESHOLD SOUND PRESSURE LEVELS FOR THE WELCH ALLYN AUDIOSCOPE" WRITTEN BY GORDON R. BENVENUE, PAUL L. MICHAEL AND JANIE D. CHAFFINCH. NOTE: THE SET POINT FOR THE 500 Hz TONE WAS CHANGED FROM 34.9 TO 35.2 dB TO IMPROVE THE MANUFACTURABILITY OF THE UNIT. WHEN USING THE 1/2 INCH SPECULA AS PRESCRIBED IN THE FIGURE ABOVE, 10 dB SHOULD BE ADDED TO THE MEASUREMENTS TAKEN TO OBTAIN THE DESIRED VALUES IN THE TABLE. SEE B & K INSTRUCTION MANUAL FOR AN ADDITIONAL EXPLANATION.

FOR QC PURPOSES AND RECALIBRATION
WHEN CHECKING TONE LEVELS, CHECK EACH TONE AT EACH LEVEL TO BE WITHIN THE LEVELS SHOWN IN THE TABLE IN FIGURE 4.

RECALIBRATION
ON RECALIBRATION, ANY UNIT OUT OF SPEC SHOULD BE SET TO THE TABLE IN FIGURE 2 AND THEN CHECKED TO THE TABLE IN FIGURE 4.

SPECIAL NOTE: YELLOW L.E.D. LIGHT FLASHING IS NORMAL DURING POWER UP. THIS INDICATES THAT THE LOW BATTERY DETECTION CIRCUIT IS WORKING.

REV	DESCRIPTION	ENVOIED INIT	DATE
A	REL TO PROD ENG	S	09/06/1988
B	REV'D NOTES	S	10/16/1988
C	REV'D NOTES: ADD'D BAK	S	01/10/1988
D	REV'D NOTES: ADD'D BAK	S	01/10/1988
E	REV'D NOTES: ADD'D BAK	S	01/10/1988
F	REV'D NOTES	S	01/10/1988
G	REV'D NOTES: ADD'D FIGURE 4	S	01/10/1988
H	REV'D NOTE TO TABLE IN FIGURE 2	S	01/10/1988
J	ADD'D SPECIAL NOTE	S	02/10/1988
K	REV'D PART NOS. FROM DWG 40185	S	01/10/1988
L	REV'D PART NOS. FROM DWG 40185	S	01/10/1988
M	REV'D PART NOS. FROM DWG 40185	S	01/10/1988
N	REV'D NOTE FOR TONE CALIBRATION AND START UP	S	02/10/1988
P	REV'D NOTE TO DECIBEL TABLE IN FIGURE 4	S	02/10/1988
R	REV'D NOTE FOR QC PURPOSES AND RECALIBRATION	S	02/10/1988

PART NO.	DESCRIPTION
-	-
THESE DRAWINGS AND SPECIFICATIONS ARE THE PROPERTY OF WELCH ALLYN, INC. AND SHALL NOT BE REPRODUCED, COPIED, OR USED IN A MANNER FOR MANUFACTURE OR SALE OF EQUIPMENT OR DEVICES WITHOUT WRITTEN PERMISSION.	
DRAWN DATE	9/9/85
OR KHANDICZ	9/9/85
APPROVED DATE	9/9/85
REL TO PROD DATE	10/3/85
B CAMPAGNA	10/3/85
TITLE	AUDIO MODULE 111 TEST SPEC
DWG NO.	A00985
SCALE	1:1
SHEET	1 OF 1

REV	REVISION	DESCRIPTION	BY	CHKD	DATE	APPROVAL
A		REL TO PROD ENG	J. Camp	CRW	1/18/68	RFB
B		REV NOTES 2 & 3, ADD 4	J. Camp	SB	1-18-68	



B&K SOUND EQUIPMENT CALIBRATION (BAND PASS FILTER TYPE 1618, MEASURING AMPLIFIER TYPE 2610):

1. SETTINGS FOR BAND PASS FILTER:
- SELECTIVITY: BANDWIDTH 1/1 OCTAVE, RECORD STEP 1/3 OCTAVE
 - RANGE: 2 Hz-20 KHz-A-LIN (DOWN)
 - FILTER CONTROL MODE: MANUAL (UP)
 - RECORDER: NO LIGHTS
 - MANUAL FILTER SELECTOR: 250 Hz

2. SETTINGS FOR MEASURING AMPLIFIER TYPE 2610:

- INPUT SECTION GAIN (CALIBRATION) = 0 dB
- INPUT SECTION GAIN (TEST) = 50 dB
- OUTPUT SECTION GAIN (CALIBRATION) = 0 dB
- OUTPUT SECTION GAIN (TEST) = 30 dB
- INPUT PRE-AMP: (UP)
- REF: OFF (DOWN)
- POL. VOLT: 200V (DOWN)
- FILTERS: EXT ON, 22.4 OFF, A OFF
- AVERAGING TIME: FAST
- DETECTOR: NORMAL (UP), HOLD (DOWN), PEAK (DOWN)

3. SETTINGS FOR DATALOGGING MULTIMETER (AWS MODEL DML-4020):

SET THE METER TO THE DC VOLTAGE RANGE AND READ AS A REGULAR METER. PRESSING THE START BUTTON WILL PRINT OUT THE CURRENT READING ON THE METER.

CALIBRATION PROCEDURE:

SWITCH PISTON PHONE SWITCH (TYPE 4220) FROM "ON" TO "BATTERY" MAKING SURE THERE IS A CLEAR AUDIBLE INCREASE IN SPEED. THIS IS A BATTERY CHECK. IF INCREASE IS NOT NOTED, REPLACE BATTERIES. SLIP BLACK COVER ON END OF PISTON. CAREFULLY REMOVE 1/2" MIC (TYPE 4134) FROM FIXTURE - PLACE SCREEN ADAPTER ON MIC - PLACE MIC IN END OF PISTON PHONE - TURN PISTON PHONE "ON" - ADJUST INPUT PREAMP ON MEASURING AMPLIFIER TO SETTING ACCORDING TO CHART BELOW - REPLACE SCREEN ADAPTER IN STORAGE BOX - PLACE FIXTURE AND MIC TOGETHER - PLACE PISTON PHONE IN STORAGE BOX.

INPUT PREAMP SETTINGS:

IF AMBIENT PRESSURE IS: *	SET INPUT PREAMP TO:
-0.05 TO -0.15 dB	4.38 VDC
-0.15 TO -0.25 dB	4.39 VDC
-0.25 TO -0.35 dB	4.37 VDC
-0.35 TO -0.45 dB	4.36 VDC
-0.45 TO -0.55 dB	4.35 VDC

WHEN TAKING TEST READINGS, THE INPUT AND OUTPUT GAIN SELECTORS SHALL BE SET AT 50 AND 30 RESPECTIVELY, AND THE MANUAL FILTER SELECTOR SHALL BE ADJUSTED TO EACH FREQUENCY AS IT IS BEING TESTED.

* B & K BAROMETER IS ALSO GRADUATED IN dB

4. AUDIBLE TONE TEST:

- SETTINGS FOR BAND PASS FILTER TYPE 1618
- ALL THREE FILTERS "OFF"
- SETTINGS FOR MEASURING AMPLIFIER TYPE 2610
- INPUT SECTION GAIN = 10dB
- OUTPUT SECTION GAIN = 0dB
- SETTINGS FOR CROWN AMPLIFIER TYPE PL - 2

dB HL	SETTING
20	40
25	45
40	52

MATERIAL: ~~~~~		FINISH: ~~~~~		QTY	QTY	QTY	QTY	ITEM	PART NUMBER	DESCRIPTION
				804	805	806	807	SYMBOL		LIST OF MATERIAL
UNLESS OTHERWISE SPECIFIED, DIMENSIONS ARE IN INCHES				DRAWN BY MOUNICZ		DATE 1/18/68		WELCH ALLYN, INC.		
TOLERANCES ON:				CHECKED				SKANEATELES FALLS, N.Y. U.S.A.		
FRACTIONS: .XX .XXX				B CAMPAGNA		2-9-68		TITLE: AUDIOSCOPE III SOUND EQUIPMENT CALIBRATION AND SETUP PROCEDURE		
UP TO 6 ± .02 ± .008				APPROVED		RR BLACK		2-9-68		
6 TO 24 ± .00 ± .010										
ABOVE 24 ± .00 ± .015										
ANGLES: ± 1/2 DEGREE										
DO NOT SCALE				REL. FOR PROD.		2-10-68		SCALE NONE		SHEET 1 OF 1
GROUP OR PART				NEXT ASS'Y		QTY USED ON		DRAWING NO. A01825		REV. B
APPLICATION								C		

REV 2 A

THESE DRAWINGS AND SPECIFICATIONS ARE THE PROPERTY OF WELCH ALLYN, INC. AND SHALL NOT BE REPRODUCED, OR COPIED, OR USED AS A BASIS FOR MANUFACTURE OR SALE OF EQUIPMENT OR DEVICES WITHOUT WRITTEN PERMISSION.

REV	REVISION	DESCRIPTION	ECN	INIT	DATE	APPROVAL
B	RETYPE & REV'D. NOTE 3; ADD'D NOTES 3, 4 & 5		5-14835	CFH	3-20-87	<i>CFH</i>

At the completion of assembly, the following must be done to the stand:

1. Plug in a 71040 Charger into the jack and plug the charger into 120V A.C.
2. Insert a production model AudioScope handle (complete with battery) into the charging well and the L.E.D. shall immediately become illuminated.
3. Move handle around in a circular motion inside well, three times clockwise and three times counter clockwise.
4. Tip charging stand with handle inserted between 30° to 45° off axis. Then rotate charging stand so handle wobbles for three turns each direction.
5. If L.E.D. does not flicker consistently in same position or go out completely, unit is to be judged acceptable.
6. Repeat Steps 2 thru 5 using a production model Tympanometer handle (complete with battery).

MAY 24 1987

		UNLESS OTHERWISE SPECIFIED DIMENSIONS ARE IN INCHES		DRAWN JD		DATE 3-20-87		WELCH ALLYN, INC. SKANEATELES FALLS, N.Y. U.S.A.				
		TOLERANCES ON:		CHECKED				TITLE: CHARGING STAND ELECTRICAL TEST SPEC				
		BASIC DIMENSION	.XX	.XXX	APPROVED <i>JH</i>		3/24/87					
		UP TO 6	± .02	± .005	REL. FOR PROD.				CODE IDENT. 64475	A	DRAWING NO. A00942	REV. B
		ABOVE 6 TO 24	± .03	± .010								
		ABOVE 24	± .06	± .015								
NEXT ASS'Y	QTY	ANGLES: ± °, DEGREE		DO NOT SCALE		SCALE		~		SHEET 1 OF 1		
APPLICATION		METRIC = ()										

THIS DRAWING AND SPECIFICATIONS ARE THE PROPERTY OF WELCH ALLYN, INC. AND SHALL NOT BE REPRODUCED, OR COPIED, OR USED IN A MANNER FOR MANUFACTURE OR SALE OF EQUIPMENT OR SYSTEMS WITHOUT WRITTEN PERMISSION.

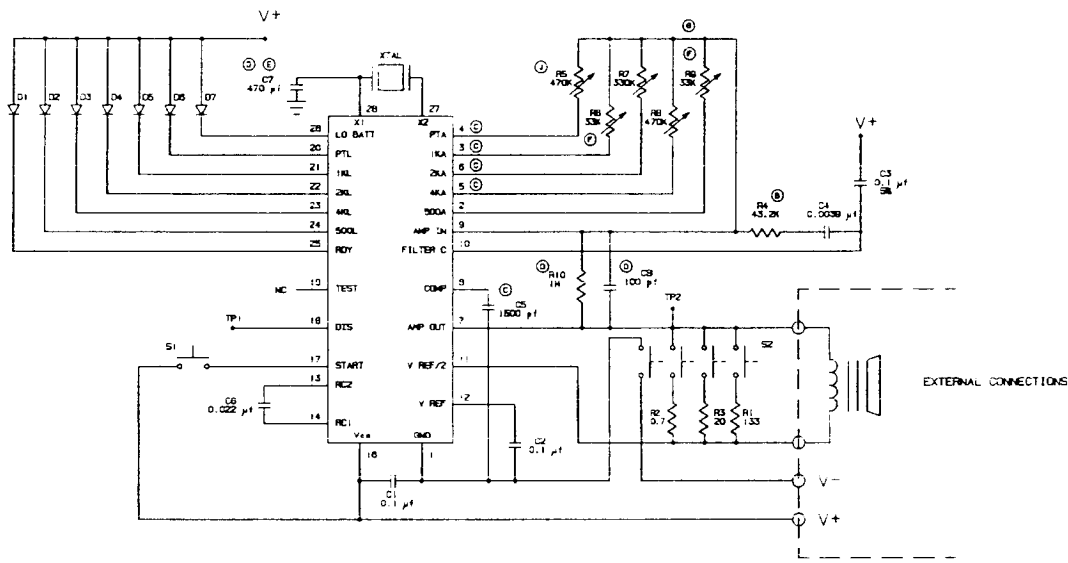

REV	REVISION	DESCRIPTION	SKCH	DATE	APPROVAL
A		REL TO PROO END	JJC	9/30/88	FRD
B		43.2 K WAS 43 K (R4)	JJC	11/11/88	JJS
C		1500pF WAS 47pF (C3) REV'D FOR-OUT. NATURE REV'D CONNECTION TO CS	JJC	12/12/88	JJS
D		ADDED C7, C8 & R10	JJC	3/19/87	JJS
E		470pF WAS 1500pF (C7)	JJC	5/28/87	FRD
F		R5 & R8 WERE 33K	JJC	9/30/87	JJS
G		33K WAS 22K (R8)	JJC	5/3/88	JJS
H		C3 WAS 0.01uF, R2 WAS 11K R1 WAS 15K, R8 WAS 22K, R9 WAS 33K	JJC	7/14/88	JJS
J		470K WAS 330K	JJC	7-8-94	JJC

HIGHEST
REF DESIG
C8
C7
R10
R2
R1
TP2

MATERIAL		FINISH		QTY	DEV	QTY	ITEM	PART NUMBER		DESCRIPTION			
				SOB	SOB	SOB	OR			LIST OF MATERIAL			
REF. DIMS	VALUES OTHERWISE SPECIFIED:												
	METRIC DIMENSIONS (WHEN USED) ARE IN ()												
	DIMENSIONS INCLUDE PLATING												
	BENDS SURF & SHARP EDGES												
	THREADS ARE UNFINISHED												
	AND INCLUDE PLATING												
EXTERNAL THERM - CLASS 2 A													
EXTERNAL THERM - CLASS 2 B													
GROUP	NEXT ASSY	QTY	USED ON	APPLICATION			DO NOT SCALE						
PART													
								DRAWN BY		DATE		DESCRIPTION	
								OR MCDONOVICZ		8/5/88		WELCH ALLYN, INC.	
								DESIGNED		J SAROFTEEN 8/12/88		BRANDELS FALLS, N.Y. U.S.A.	
								APPROVED		P BLACK 8/12/88		TITLE	
												AUDIO II	
												SCHEMATIC	
								SCALE		DRAWING NO.		REV	
								0 CAMPALINA 10/2/88		230230		J	
								SCALE				PAGE 1 OF 1	

THIS DRAWING AND SPECIFICATIONS ARE THE PROPERTY OF WELCH ALLYN, INC. AND SHALL NOT BE REPRODUCED OR COPIED, IN WHOLE OR IN PART, FOR NEITHER THE USE OF NEITHER OR WITHOUT WRITTEN PERMISSION.

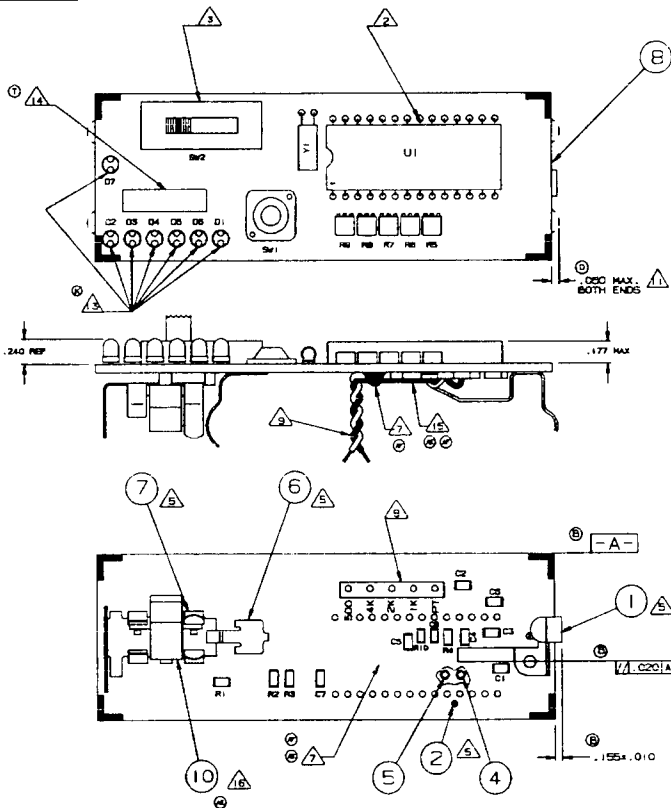

L.E.D. MOUNTING DETAIL



NOTES:

1. COMPONENTS ARE TO BE LOCATED AS SHOWN, AND MOUNTED SO AS TO MINIMIZE THE DISTANCE BETWEEN THE COMPONENTS AND THE PCB.
2. FOUR CORNER LEADS ARE TO BE CLINCHED INWARD ON THE IC.
3. ALL COMPONENTS EXCEPT FOR RS-RS, SW1 AND SW2 ARE TO BE WAVE SOLDER ATTACHED TO PCB USING A 60/40 EUTECTIC SOLDER. RS-RS ARE TO BE REFLOW SOLDERED ON TOP OF PCB USING THE APPROPRIATE SOLDER PASTE. SW1 AND SW2 ARE TO BE ATTACHED AFTER WAVE AND REFLOW SOLDERING AND CLEANING OPERATIONS HAVE BEEN COMPLETED. WILCOBIN SWITCH LUBRICANT TO BE APPLIED TO PCB UNDER SWITCH MECHANISM. APPLY 0.2CC OF LUBRICANT HERE.
4. AN AQUEOUS BASE FLUX IS TO BE USED DURING THE SOLDERING OPERATIONS, AND FLUX REMOVAL AFTER SOLDERING SHOULD BE DONE WITH AN AQUEOUS BASED CLEANING SOLUTION. BE SURE THAT THE ASSEMBLY IS FREE OF ANY RESIDUAL CLEANING FLUID.
5. ITEMS 1, 2, 4, 5, 6 AND 7 ARE TO BE SOLDER ATTACHED TO PCB USING A 60/40 EUTECTIC SOLDER. THESE COMPONENTS CANNOT BE WAVE SOLDERED. A HAND SOLDERING OPERATION IS RECOMMENDED.
6. TEST ASS'Y PER. A00694.
7. TAB PROTRUSIONS LEFT AFTER REMOVAL FROM ARRAY ALLOWED ON SHORT EDGES ONLY AS SHOWN.
8. BOARD IS TO BE "BURNED IN" FOR A MINIMUM OF 24 HOURS AT 140°F TO FILTER OUT INFANT FAILURES. TEST SPECIFICATIONS (A00694) ARE TO BE MET AFTER BURN IN PERIOD. A TEST DATA SHEET SHOWING CONFORMANCE TO A00694 IS TO ACCOMPANY EACH UNIT.
9. ANODE OF LED'S (LONGER LEAD) TO BE LOCATED IN THESE LOCATIONS.
10. ANY VENDOR LOT OR RUN LABELING MAY BE LOCATED IN THIS AREA. MARK WITH ASSEMBLY NO., DASH NO., REVISION LETTER AND DATE CODE (YYMM).
11. ITEMS 4 AND 5 FLUSH AGAINST BOARD BETWEEN SOLDERED END AND TACK LOCATION.
12. SNAP ITEM 10 (LAMP EJECTOR) INTO PLACE BY SPREADING PRONGS OF ITEM 7 (LAMP HOLDER).
13. ASSEMBLY IS TO CONFORM TO IPC 810 AND QAP 150 WORKMANSHIP STANDARDS.

REV	REVISION	DESCRIPTION	BY	DATE	APPROVAL
A	REL. TO PROD. ENG.				
B	ADD NOTE 10, 11, 12, 13, 14, 15		JJS	8/23/88	RFD
C	REV'D PCB BOARD		JJS	10/15/88	JJS
D	ADD 2ND HOLE BOTH ENDS WITH NOTES 11 & 12		JJS	12/12/88	JJS
E	ADD C7, C8 & R10 TO SW1		JJS	3/19/87	RFD
F	CHNG C7 TO 470 pF		CRV	5/28/87	JJS
G	B/W CHNG U1		JJS	7/11/87	RFD
H	ADDED C7, C8 & R10 TO VIEW		JJS	7/10/87	JJS
I	CHANGED TEST SPEC. A00694		JJS	9/8/87	JJS
J	ADDED NOTE 13.		JJS	9/9/87	JJS
L	ADD A00694, 230210 & BOM FOR REV. 3 & 5		CRV	9/30/87	JJS
M	ADD DATE OF BURN-IN TO NOTE 10		CRV	10/5/87	RFD
N	CHANGED 230210		JJS	10/5/87	RFD
P	REV'D NOTE 7		CRV	12/8/87	RFD
R	CHANGED 230210 & A00694		CRV	12/8/87	RFD
T	REV'D NOTE 2; ADD NOTE 14		CRV	3/3/88	JJS
U	CHANGED ITEMS 4 & 5 TO 2ND ANGLE		JJS	5/28/88	JJS
V	MAKE 230211 A REF. DWG.		EVA	7/18/88	BAC
W	REV'D A00694 & 230210 VALUED UP TO REV. 3 & 5		CRV	7/18/88	JJS
X	REVISED QTY 230206 AS PER VENDOR REQUEST		JJS	8-18-88	JJS
Y	CHANGE 230211 TO 230207		RDB	8-17-88	JJS
AA	MAKE 230206, 230207, 230207, & 230208 REF. DWG.		JJS	9/14/88	BAC
AB	CHANGED 230206		JJS	10/25/88	JJS
AC	REV'D DWG A00694		CRV	12/8/88	JJS
AD	80°/45° WAS 90°/45° (LED)		JJS	2/21/89	BAC
AE	REV'D NOTE 1, ADD NOTE 15. 8 AND 10 TO REV. 3 & 5		CRV	10/17/88	JJS
AF	REV'D NOTE 7, 12 & 15		CRV	12/18/88	JJS
AG	REV'D 230206, 230207 & 230208		SB	1-8-90	KJB
AH	REV'D NOTE 14, REV 14		SB	11-22-93	AJK
AJ	REV'D BOM, CHANGED RS FROM 330K TO 240K		CRV	10/26/94	

THIS DWG-502		PC BOARD ASS'Y	
QTY	CITY	QTY	DESCRIPTION
REV	REV	REV	REV
LIST OF MATERIAL			
DRAWN: M. G. SMITH		DATE: 8/12/88	
CHECKED: J. SAROFEEN		DATE: 8/12/88	
APPROVED: R. BLACK		DATE: 8/12/88	
TITLE: PC BOARD ASS'Y		DRAWING NO. 230215	
SCALE: 2:1		SHEET 1 OF 1	

MATERIAL	FINISH	QTY	UNIT	USED ON
UNLESS OTHERWISE SPECIFIED:				
METRIC DIMENSIONS (WHEN USED) ARE IN ()				
CONFORM TO BOLLER PLATING				
REMOVE BURRS & SWAP EDGES				
THREADS ARE UNAPPLIED				
AND INCLUDE PLATING				
EXCEPTION: THIS = CLASS-2 & INTERNAL THIS = CLASS-3 &				
GROUP PART	NEXT ASCT	QTY	USED ON	
APPLICATION				

LOW BATTERY INDICATION

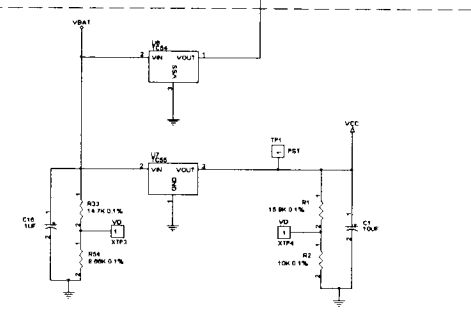
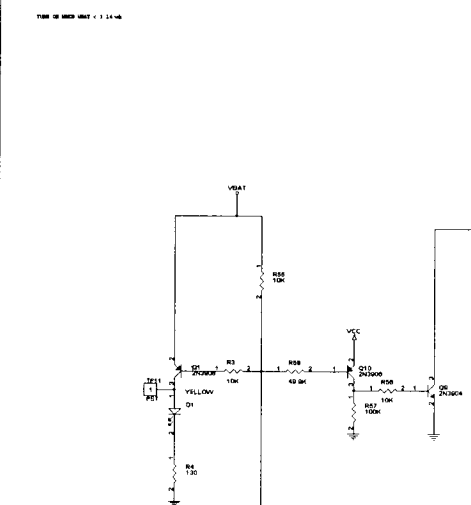

POWER SUPPLY

MICRO-CONTROLLER

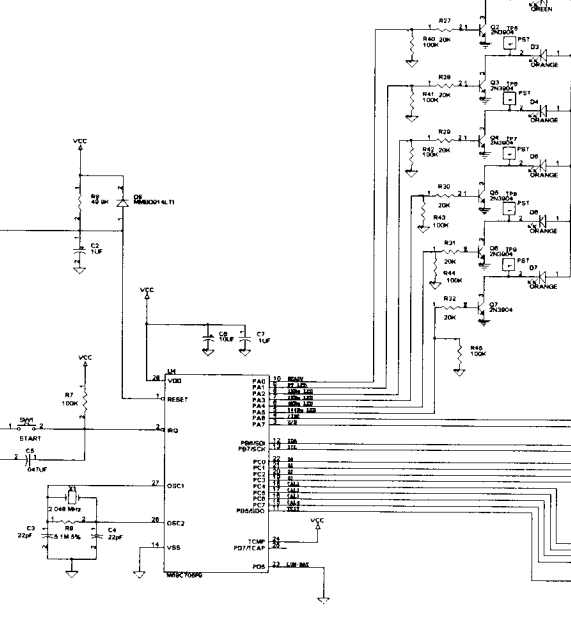

tone GENERATION & AMPLIFIER

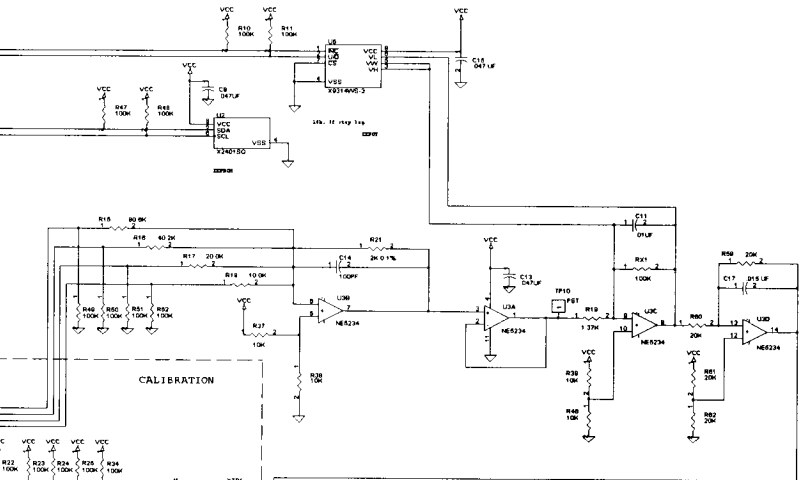

CALIBRATION



LEVEL SELECTION



NOTES

- Parts and values are for reference only. Use BOM for actual manufacturing information.
- For all resistors:
R1 - 100 Ohms
R2 - 200 Ohms
R3 - 300 Ohms
R4 - 400 Ohms
R5 - 500 Ohms
R6 - 1K Ohms
R7 - 2K Ohms
R8 - 3K Ohms
R9 - 4K Ohms
R10 - 5K Ohms
R11 - 10K Ohms
R12 - 20K Ohms
R13 - 30K Ohms
R14 - 40K Ohms
R15 - 50K Ohms
R16 - 100K Ohms
R17 - 200K Ohms
R18 - 300K Ohms
R19 - 400K Ohms
R20 - 500K Ohms
R21 - 1M Ohms
R22 - 2M Ohms
R23 - 3M Ohms
R24 - 4M Ohms
R25 - 5M Ohms
R26 - 10M Ohms
R27 - 20M Ohms
R28 - 30M Ohms
R29 - 40M Ohms
R30 - 50M Ohms
- For all capacitors:
C1 - 100pF
C2 - 200pF
C3 - 300pF
C4 - 400pF
C5 - 1nF
C6 - 2nF
C7 - 3nF
C8 - 4nF
C9 - 5nF
C10 - 10nF
C11 - 20nF
C12 - 30nF
C13 - 40nF
C14 - 50nF
C15 - 100nF
C16 - 200nF
C17 - 300nF
C18 - 400nF
C19 - 500nF
C20 - 1µF
C21 - 2µF
C22 - 3µF
C23 - 4µF
C24 - 5µF
C25 - 10µF
C26 - 20µF
C27 - 30µF
C28 - 40µF
C29 - 50µF
C30 - 100µF
- When other values are indicated, use the value in the BOM.
- All BOM & PWB are for Assembly purposes.

DATE	INITIALS	DATE	INITIALS	DATE	INITIALS
DESIGNED	SLV	CHECKED	SLV	DATE	5/17/88
APPROVED	CCF	DATE	5/17/88	PROJECT	SCHEMATIC 23060220N
DATE	5/17/88	DATE	5/17/88	PROJECT	LIBRARY 23060220N
DATE	5/17/88	DATE	5/17/88	PROJECT	PLOT 23060220N
DATE	5/17/88	DATE	5/17/88	PROJECT	SCHEMATIC ELECTRICAL SCHEMATIC
DATE	5/17/88	DATE	5/17/88	PROJECT	LIBRARY 23060220N
DATE	5/17/88	DATE	5/17/88	PROJECT	PLOT 23060220N
DATE	5/17/88	DATE	5/17/88	PROJECT	SCHEMATIC ELECTRICAL SCHEMATIC
DATE	5/17/88	DATE	5/17/88	PROJECT	LIBRARY 23060220N
DATE	5/17/88	DATE	5/17/88	PROJECT	PLOT 23060220N
DATE	5/17/88	DATE	5/17/88	PROJECT	SCHEMATIC ELECTRICAL SCHEMATIC

LAMP DRIVER

